

Phase 1: A Journey to Mir 1994~1998

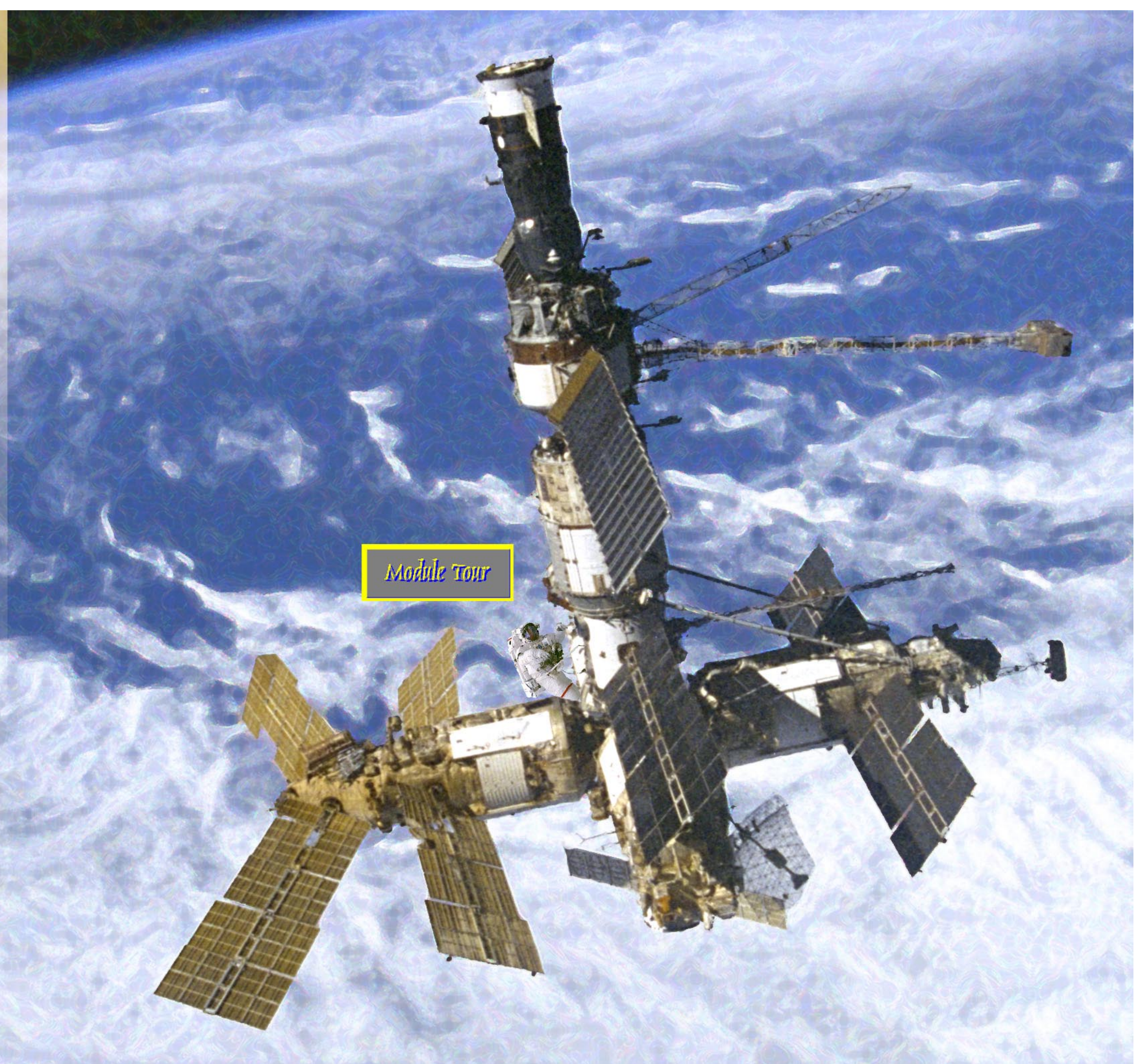

Module Tour

List of Experiments

List of Experiments by Increment

COSMIC RADIATION EFFECTS AND ACTIVATION MONITOR (CREAM)

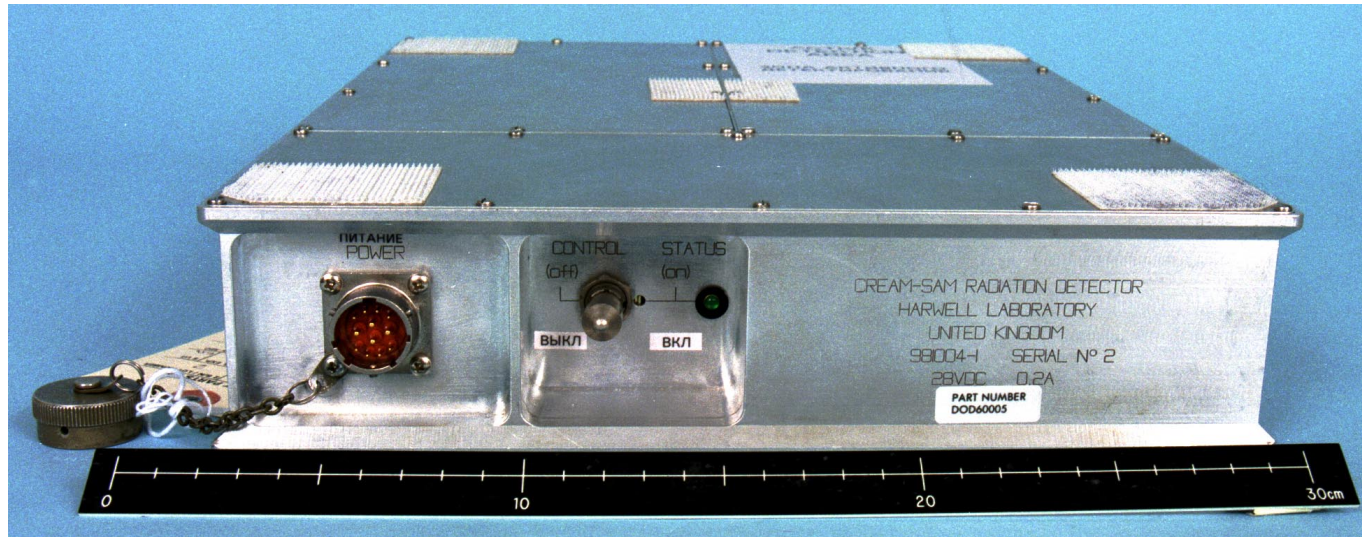

Figure ISS-1 CREAM in the Shuttle

S97-04353

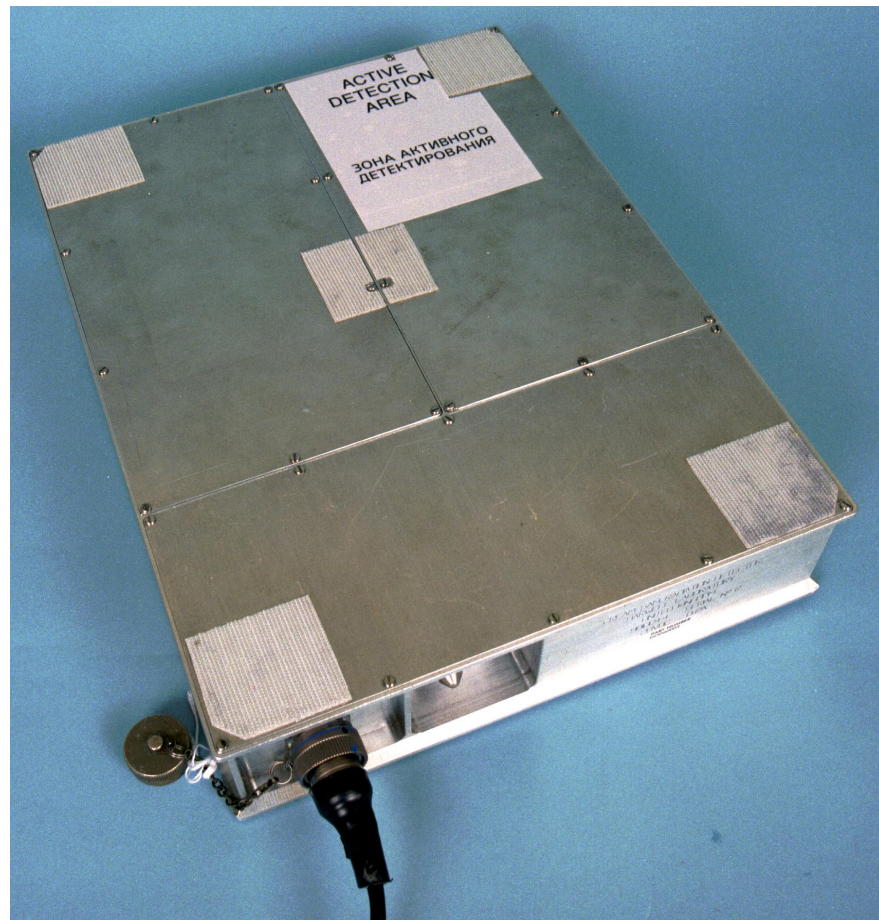

Figure ISS-2 CREAM Active Monitor Main Panel

S97-04354

EXPERIMENT DESCRIPTION

The Mir modules, and later the International Space Station, represent opportunities to explore new radiation environments in order to obtain data on different shielding levels and the effects of radiation on larger spacecraft. The Cosmic Radiation and Effects Activation Monitor (CREAM) measures the Linear Energy Transfer (LET) effects within silicon and provides information relevant to single event upsets on avionics equipment.

SCIENCE OBJECTIVES

1. To monitor the energy disposition spectra in silicon due to primary and secondary radiation as a function of time, orbital location and shielding.
2. To obtain collateral data on mission integrated dose, particle influences, and induced radioactivity.
3. To improve and test space environment and radiation shielding codes used to predict single event upset rates in electronics and background rates in sensors.

FUNCTIONAL OBJECTIVES

1. Transfer 10 Dosimeters to Mir after docking.
2. Deployment.
3. Activation in the Commander's Cabin, Kristall, and Kvant II.
4. Deactivation. 5 Dosimeters.
5. Transfer 5 Dosimeters in passive mode on Mir to Shuttle prior to undocking. Leave.

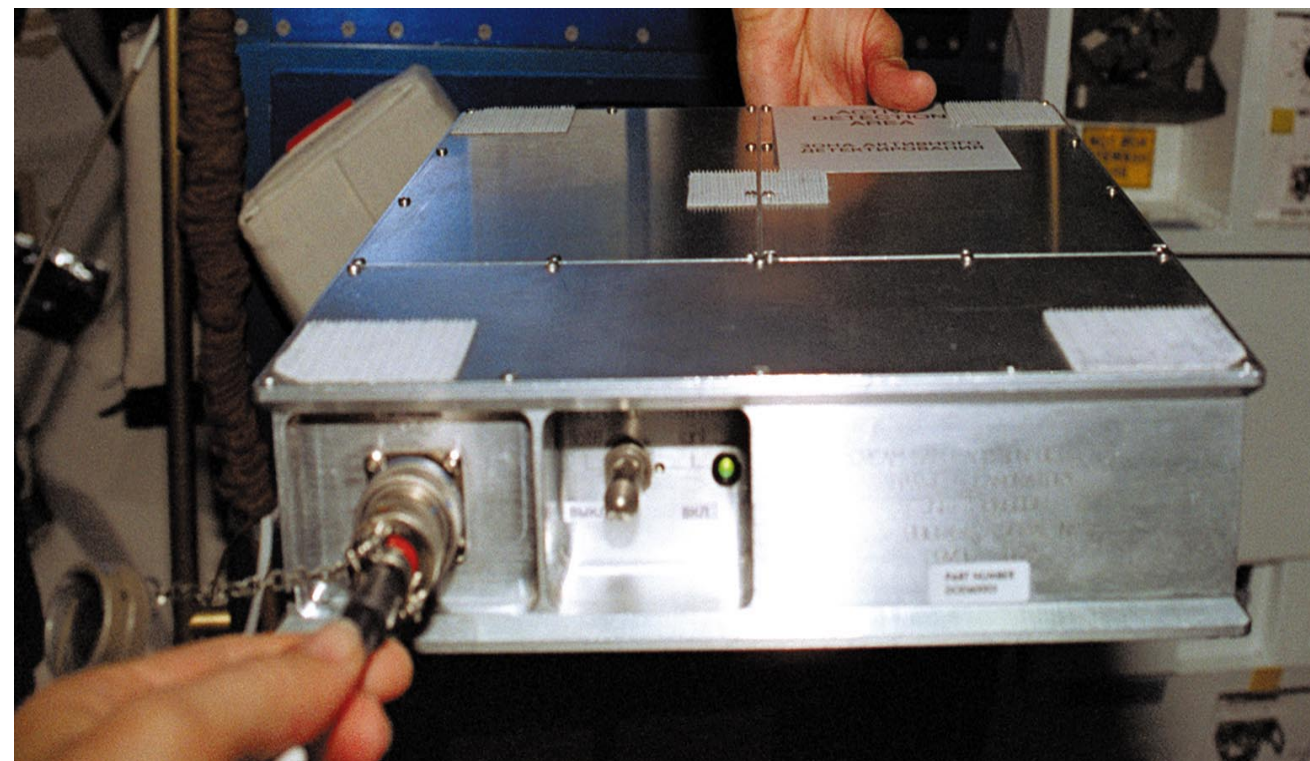

Figure ISS-3 CREAM Active Monitor Bottom

STS84-379-010

D.I.D.

Cosmic Radiation Effects and Activation Monitor

Principal Investigator:

Amie Tavanese
Air Force
Captain
(281)483-3506

Peter Truscott (U.K.)
011-44-1252-393-290

COSMIC RADIATION EFFECTS AND ACTIVATION MONITOR

P/N: DOD60005
Qty: 2
Mass: 4.2 kg (ea)
Power: 1.6 W
x,y,z: 38.1 x 29.2 x 7.3 cm
Loc: Base Block
DID: SLM46115574
Start-up Current:
6.6 amps 23 msec
On-Board Electrical Supply:
28 Vdc power supply
Insulation Resistance:
20 MOhm
(1 MOhm high humidity)
Operational Life:
1344 hours
Shelf Life:
5 years



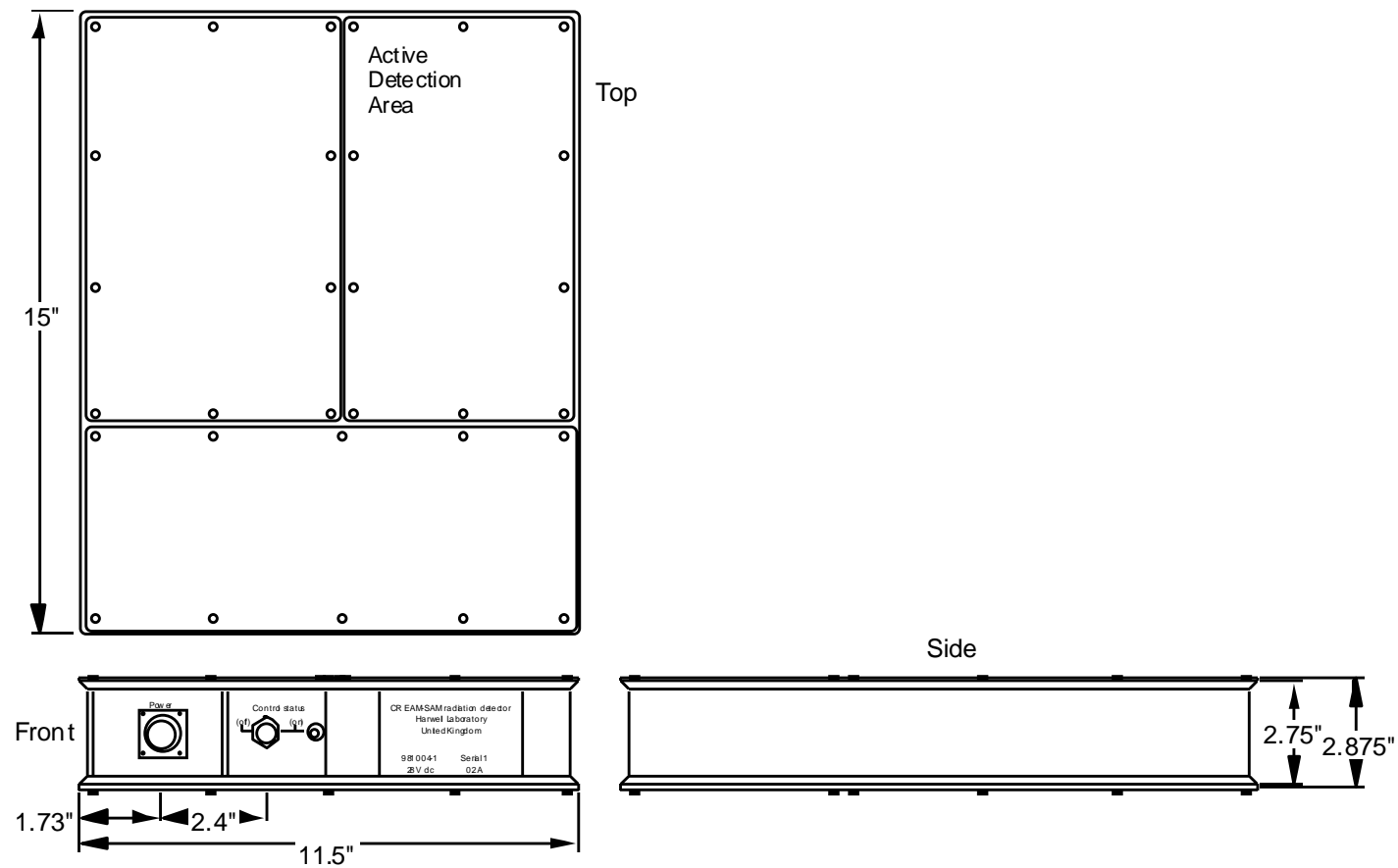
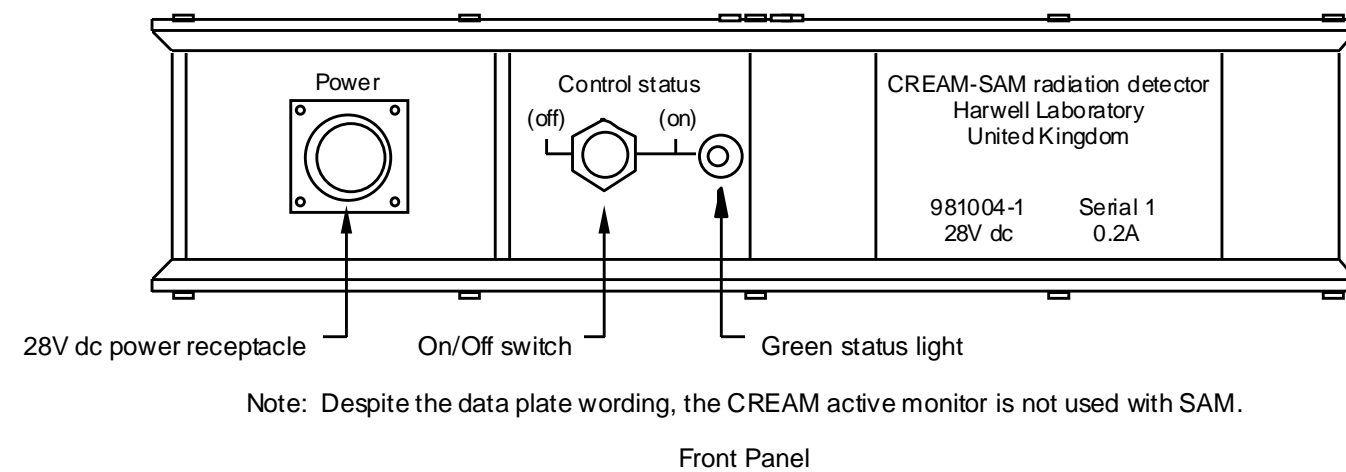

TABLE ISS.1
EXPERIMENT FLIGHT HARDWARE

HARDWARE TITLE	PART #/SERIAL #
Passive Detector Packages	DOD80011A
Passive Crystal Scintillation Canister	DOD60017
Passive Neutron Spectrometer	DOD60018
Active Monitor	DOD60005 - SN1
Active Monitor	DOD60005 - SN2
MIR Standard Long Power Cable	SEM46114428-301
DC Power Cable ("Y" CABLE)	SEM46111035-301
Transfer bags	SKD13101494-305

TABLE ISS.2
DEFINITION OF CREAM/SHUTTLE THRESHOLDS
IN CRITICAL CHARGE (Q_c), TOTAL ENERGY DEPOSITION,
AND NORMAL INCIDENCE LET

Channel	Active Monitor Serial #1			Active Monitor Serial #2		
	Q_c [pC]	Energy [MeV]	LET Threshold [MeVcm ² g ⁻¹] (silicon)	Q_c [pC]	Energy [MeV]	LET Threshold [MeVcm ² g ⁻¹] (silicon)
1	0.020	0.41	6.27	0.021	0.43	6.76
2	0.048	0.98	15.0	0.051	1.04	16.4
3	0.111	2.29	34.8	0.118	2.43	38.0
4	0.264	5.41	82.8	0.281	5.76	90.5
5	0.625	12.9	279	0.666	13.7	214
6	1.49	30.5	467	1.59	32.6	511
7	3.53	72.3	1110	3.77	77.2	1210
8	8.38	172.	2630	8.93	183.	2870
9	19.9	407.	6220	21.2	434.	6810



HARDWARE DESCRIPTIONS

Flight hardware for CREAM is listed in Table ISS.1.

PASSIVE DETECTORS

There are three types of passive detectors within the complement of CREAM components: the Passive Detector Packages (PDPs), the Passive Crystal Scintillation Canister, and the Passive Neutron Spectrometer. Eight of the ten Passive Detector Packages were deployed in four distinct locations within the Mir station. The remaining two Passive Detector Packages, the two Passive Neutron Spectrometers, and the Passive Crystal Scintillation Canister will remain in the central location.

PASSIVE DETECTOR PACKAGES

Each Passive Detector Package contains four capsules, each capsule having two lithium fluoride and two aluminum oxide thermoluminescent dosimeter (TLD) chips. In addition, each PDP contains one gold (Au) and two nickel (Ni) foil-type detectors, and five neutron bubble detectors (BD-PND). These detectors are stacked together and wrapped in Kapton sheets and Kapton tape. The bubble detectors are plastic (polycarbonate) tubes which contain an elastic polymer gel throughout which super heated liquid has been dispersed. The BD-PND detectors have an energy threshold of 200 KeV to 15 MeV. The activation foils of gold (threshold of .025 eV) and nickel (threshold of 3 Mev) are used for detection of neutrons. Each package measures approximately 14.0 x 10.1 x 2.5 cm. The weight of each PDP is 0.48 kg.

PASSIVE CRYSTAL SCINTILLATION CANISTER

The Passive Crystal Scintillation Canister is an aluminum cylinder housing which contains various types of scintillation crystals. The unit measures 13.96 x 10.15 cm diameter and weighs no more than 2.6 kg. The objectives of the Passive Scintillation Crystal Canister are to 1) compare induced radioactive background in a variety of x-ray detector materials so as to assist in material selection for future x-ray astrophysics instruments, and 2) provide additional information about the neutron and proton environment and the effect of shielding.

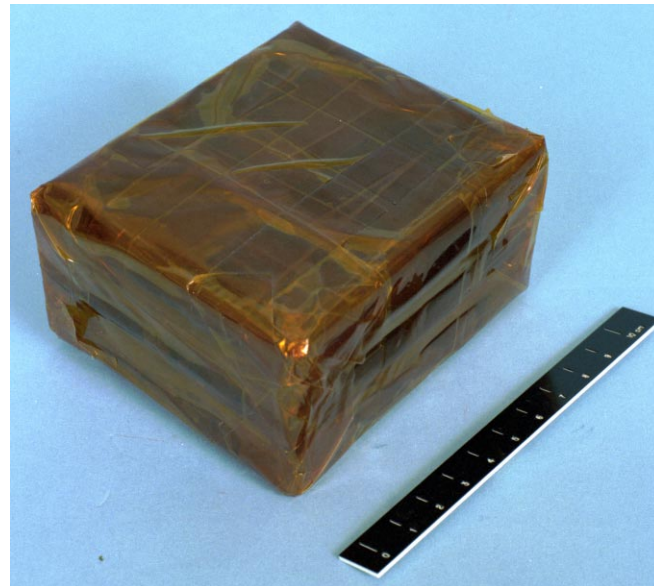

Figure ISS-5 CREAM Passive Detector Package S97-04350



Figure ISS-6 Passive Scintillation Crystal Canister S97-04351

PASSIVE NEUTRON SPECTROMETER

The Neutron Spectrometer is comprised of three sets of six Bubble Detector Spectrometer (BDS) Bubble Detectors for a total of 18 bubble detectors which have a range of energy threshold from 100 KeV to 10 MeV. The six subthresholds within the entire spectrum are 10 KeV to 20 MeV, 100 KeV to 20 MeV, 600 KeV to 20 MeV, 1 MeV to 20 MeV, 2.5 MeV to 20 MeV and 10 MeV to 20 MeV. The BDSs are similar to the BD-PND detectors in the passive detector packages, but also contain an elastic polymer gel. The eighteen tubes are wrapped in Kapton sheets and Kapton tape. The spectrometer measures 9.8 x 5.4 x 8.3 cm.

ACTIVE MONITOR

The Active Monitor is the only active component of the CREAM hardware. It is rotated between two of the Passive Detector Package locations. The Active Monitor is connected to the 28 Vdc power supply using both the Mir Standard Long Power Cable and the DC "Y" Cable. The unit is switched on with the center-locked toggle switch located on the front of the box. A green indicator light will be illuminated when the Active Monitor is powered on.

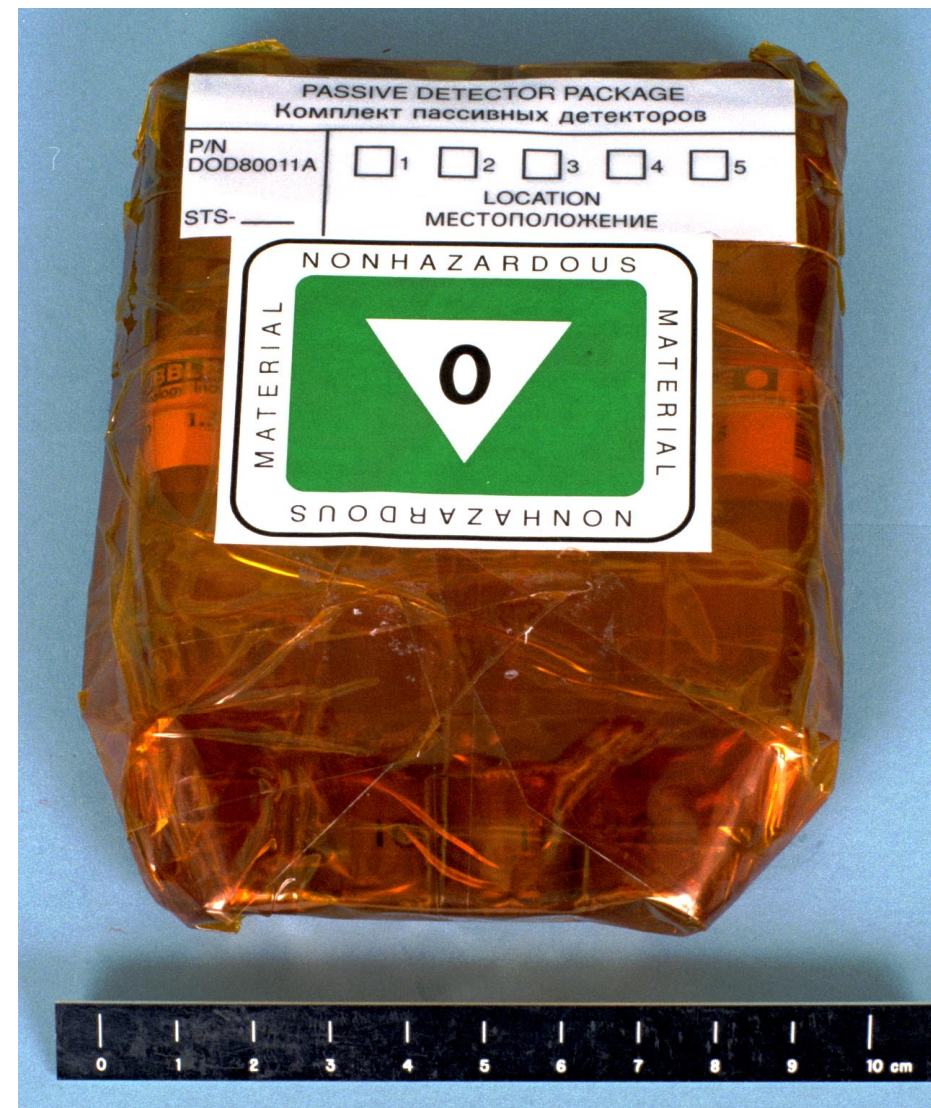

Figure ISS-7 Passive Neutron Spectrometer S97-04349

CREAM NEUTRON SPECTROMETER

P/N: DOD60018
Qty: 1
Mass: 0.41 kg
Power: N/A
x,y,z: 9.8 x 5.4 x 8.33 cm
DID#: SLM46115574

CREAM PASSIVE DETECTOR PACKAGE

P/N: DOD80011A
Qty: 5
Mass: 2.4 kg
Power: N/A
x,y,z: 38.2 x 29.2 x 7.0 cm
DID#: SLM46115574

PASSIVE CRYSTAL SCINTILLATION CANISTER

P/N: DOD60017
Qty: 1
Mass: 1.99 kg
Power: N/A
x,y,z: 13.96 x 10.15 cm
DID#: SLM46115574

PASSIVE CRYSTAL SCINTILLATION CANISTER

P/N: DOD60017
Qty: 1
Mass: 2.6 kg
Power: N/A
x,y,z: 14 x 10.6 cm
DID#: SLM46115574



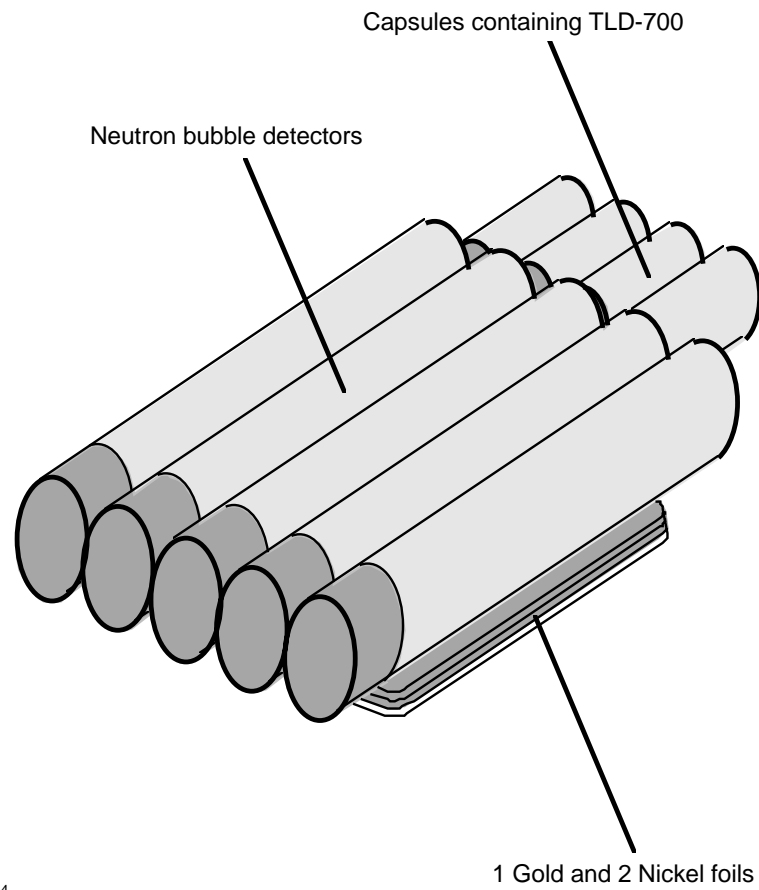

Figure ISS-8 Passive Detector Package

OPS-164

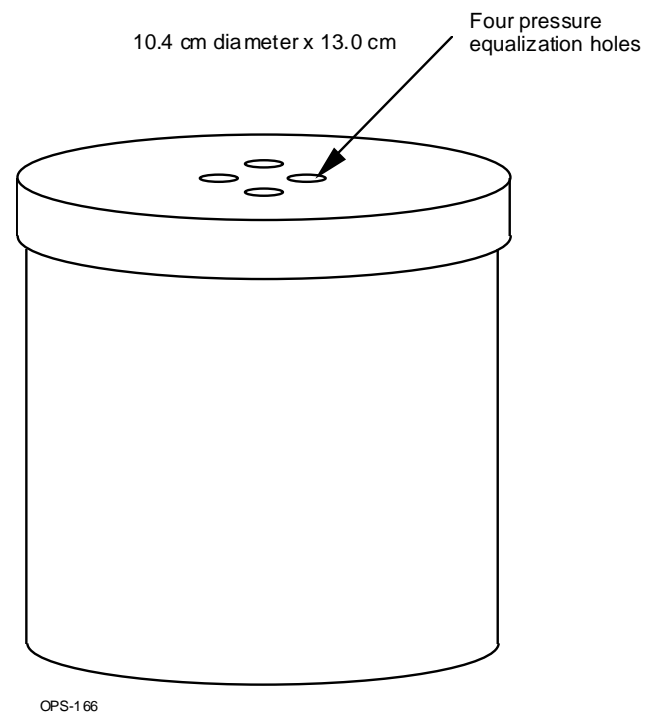

Figure ISS-9 Passive Crystal Scintillation Canister

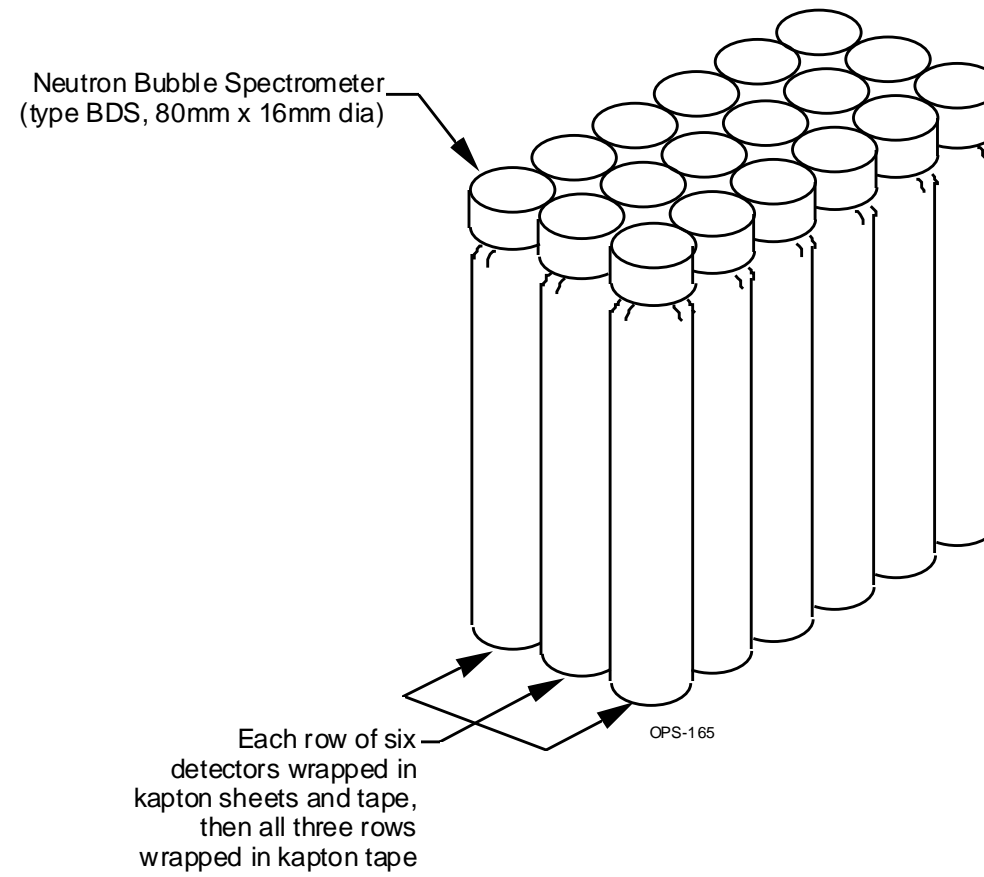

Figure ISS-10 Passive Neutron Spectrometer

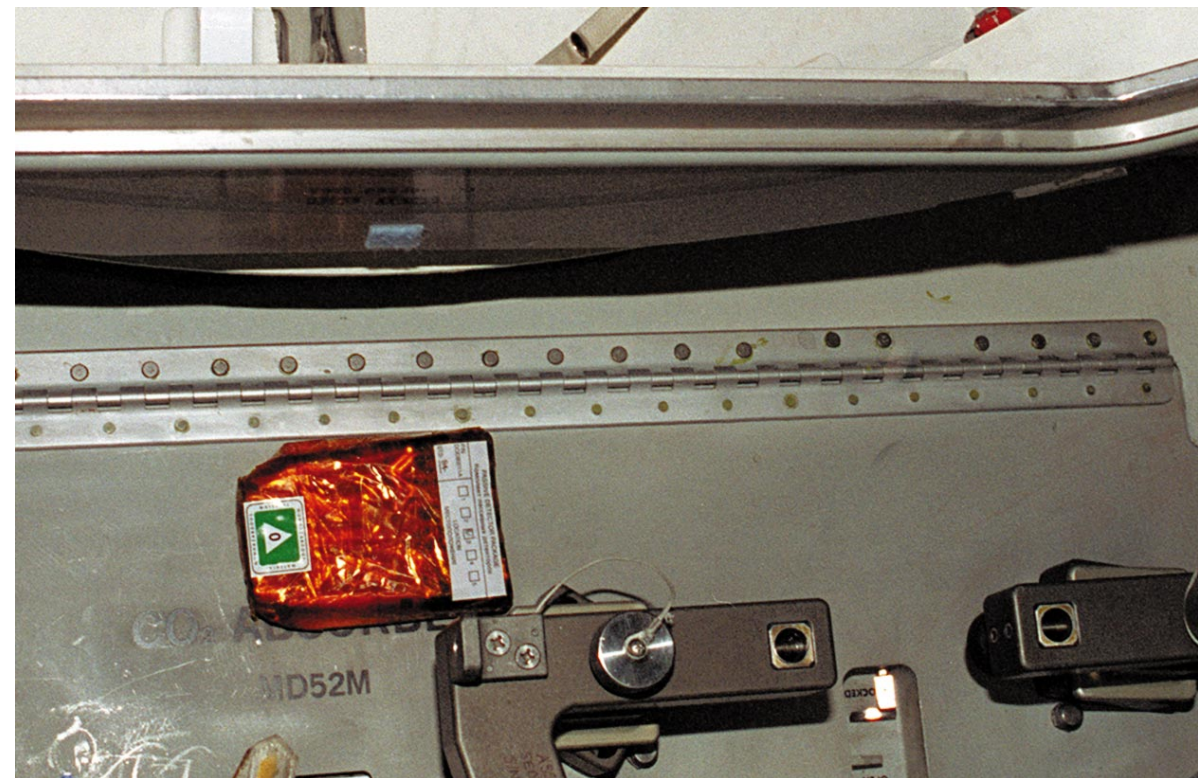

Figure ISS-11 CREAM Passive Detector Package

Note: The Passive Detector Package is wrapped in Kapton and secured together using Kapton tape.

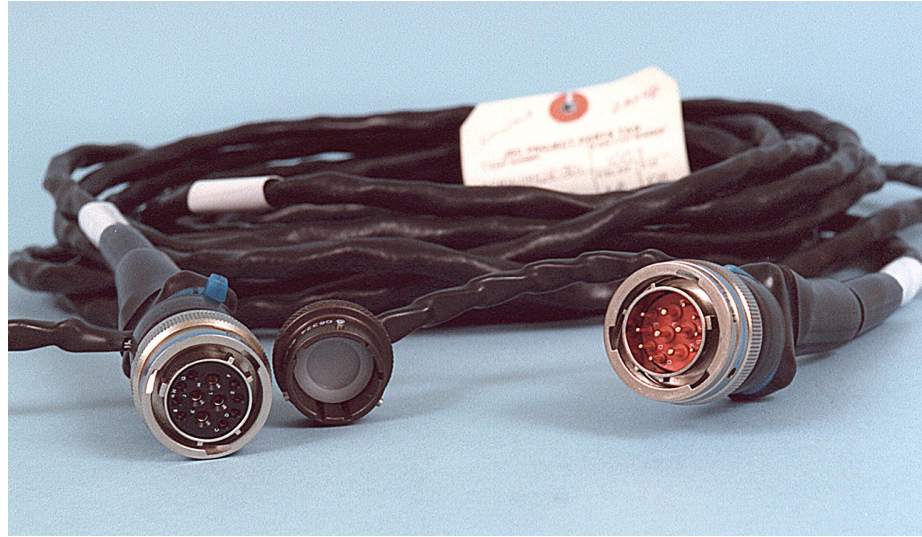

Figure ISS-12 4428 Cable

S97-10571



Figure ISS-13 4428 Cable

S97-10592



Figure ISS-14 1035 Cables

22

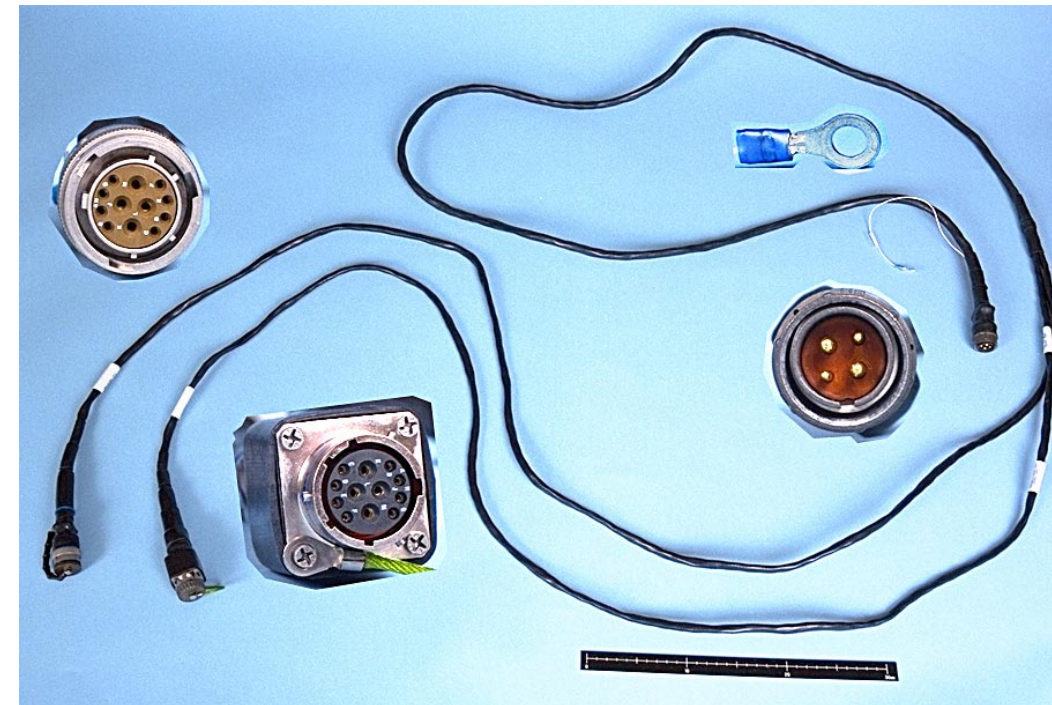

Figure ISS-15 1035 Cable Assembly

20

The outer aluminum casing of the Active Monitor measures 38.1 x 29.2 x 7.3 cm and weighs 4.2 kg. Within the unit is a 10cm² array of reverse-biased positive-intrinsic-negative (PIN) diodes which serve as a detector of protons and heavy ions. The particles are counted according to energy deposited in nine channels and data is stored in the monitor's memory.

See Table ISS.2 for a definition of CREAM/Shuttle thresholds in critical charge (Q_c) total energy deposition, and normal incidence LET.

MIR STANDARD LONG POWER CABLE

The Mir Standard Long Power Cable (4428 cable) is stored on board Priroda.

DC POWER CABLE ("Y" CABLE)

The DC "Y" Cable will connect to the Russian power receptacle and to the end of the Mir Standard Long Power Cable (1035 cable). This assembly will connect to the Active Monitor.

HARDWARE INTERFACE WITH SYSTEMS

None of the CREAM components are permanently mounted to Mir. The equipment is temporarily attached to Mir using gray tape. The deployment locations will be determined by the CREAM Principal Investigator with Russian concurrence. These deployment locations will be chosen based on current shielding and thermalizer location data. The Active Monitor will be mounted in two of the four deployment stations in two week increments for the duration of Increment 7.

The Active Monitor requires power from a DC outlet with a nominal power consumption 1.6W from 28V. There may be a peak start up load up to 6.6A for a period of 23 microsec with a nominal current of 80 mA.

The allowable supply voltage is 23 to 32 Vdc. An internal 3.0 V lithium manganese dioxide battery powers the internal clock. *

D.I.D.

Standard Utility Power Cable Assembly

DC "Y" POWER CABLES (1035)

P/N: SEM46111035-303
Qty: 2
Mass: 2.72 kg
Power: N/A
x,y,z: 30.48 x 7.62 x 30.48 cm

MIR STANDARD LONG POWER CABLE (4428)

P/N: SEM46114428-301
Qty: 2
Mass: 3.12 kg
Power: N/A
x,y,z: 900 cm (9m)
Loc: Priroda

DC "Y" POWER CABLE ASSEMBLY (1035)

P/N: SEM46111035-301
Qty: 1
Mass: 1.2 kg
Power: N/A
x,y,z: 22.8 x 22.8 x 5.1 cm
DID#: SLM46110480



ENHANCED DYNAMIC LOAD SYSTEMS (EDLS) ON MIR

EXPERIMENT DESCRIPTION

The EDLS provides a test bed for on-orbit study of nominal crew-induced forces. Former microgravity experiments have studied maximal and minimal force loads imparted by flight crewmembers. EDLS aims to characterize passive nominal forces that will benefit the design of future microgravity structures. It is therefore intended that the four Sensors (Handhold, Touch Pad, and two Foot Loops) be used as any other surface in the space vehicle so that data recorded is that of typical crew motion.

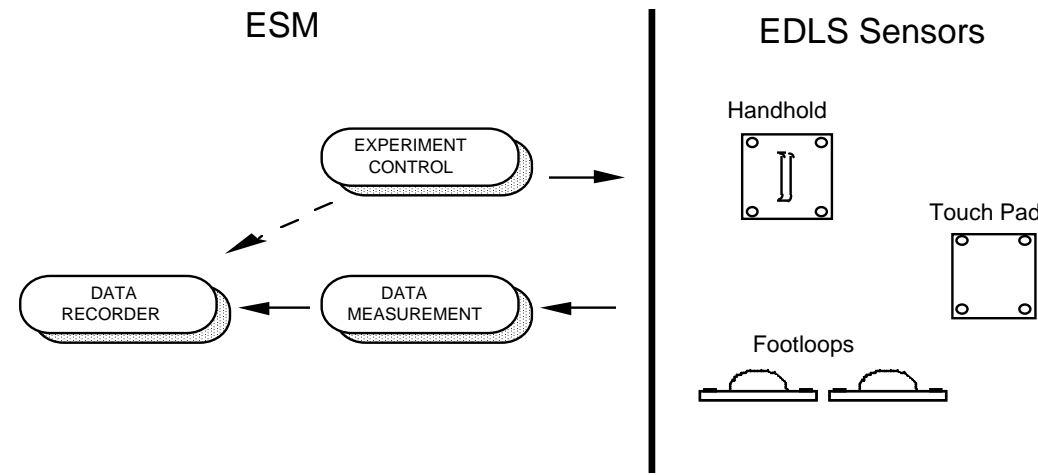

Figure ISS-17 EDLS Functional Diagram

Enhanced Dynamics Load Sensor (EDLS) Experiment Support Module (ESM)

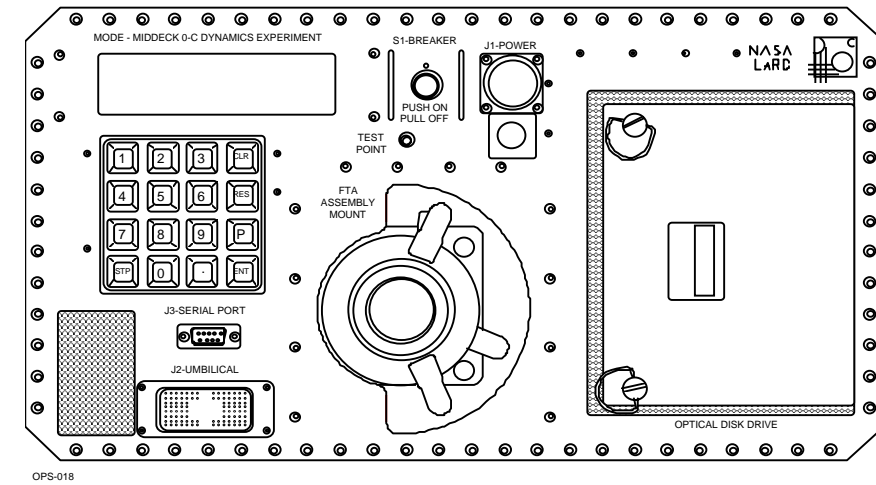

Figure ISS-18 EDLS Experiment Support Module (Which Was Unoperational) Drawing



Figure ISS-16 EDLS Hardware

S95-17026

The purpose of the EDLS experiment is to measure the nominal common forces and moments exerted by Space Station crews during their regular routine activities on board Mir. The experiment hardware is comprised of four Sensors including a Handhold, a Touch Pad, and two Foot Restraints designed to function as normal motion restraint devices. The forces and torques measured by the Sensors are written to a disk drive in the Experiment Support Module (ESM). The ESM is a unit built to the inside dimensions of a Middeck or Priroda locker. The ESM provides electronics, a computer, data storage, power supply, and signal conditioning for the experiment. See Figure ISS-17 for a functional diagram of the ESM and Sensors. Because the ESM failed during MIR 21, a new adapter was flown which allows the MiSDE ESM to be used for both EDLS and MiSDE sensors.

The data taken from Mir will allow the scientist to study more long-term effects of microgravity on crew motion and how microgravity affects the Space Station. New Event detection software was used when the MiSDE ESM was incorporated on Increment 4. This allows it to record data only when an event is applied to the sensors. It also

Principal Investigators:
Sherwin Beck
NASA/LeRC
(757)864-1966

Dr. Dava Newman
(617)258-8799

EDLS EXPERIMENT SUPPORT MODULE (ESM)

P/N: MODE-1-D10
Mass: 26.76 kg
Power: 105 W
x, y, z: 49.10 x 41.50 x 22.80 cm

EDLS HANDHOLD

P/N: MODE-2-D21
Mass: 2.39 kg
Power: .25 W
x, y, z: 24.13 x 24.13 x 9.55 cm

EDLS UMBILICAL CABLE

P/N: MODE-2-D25
Mass: 4.04 kg
Power: N/A
x, y, z: 1.91 x 76.20 cm

EDLS FOOT RESTRAINT

P/N: MODE-2-D22
Mass: 3.91 kg
Power: .25 W
x, y, z: 23.13 x 24.13 x 2.95 cm

EDLS IRIG PORT ADAPTER CABLE

P/N: MODE-3-D27
Mass: .15 kg
Power: N/A
x, y, z: 24.13 x 24.13 x .97 cm

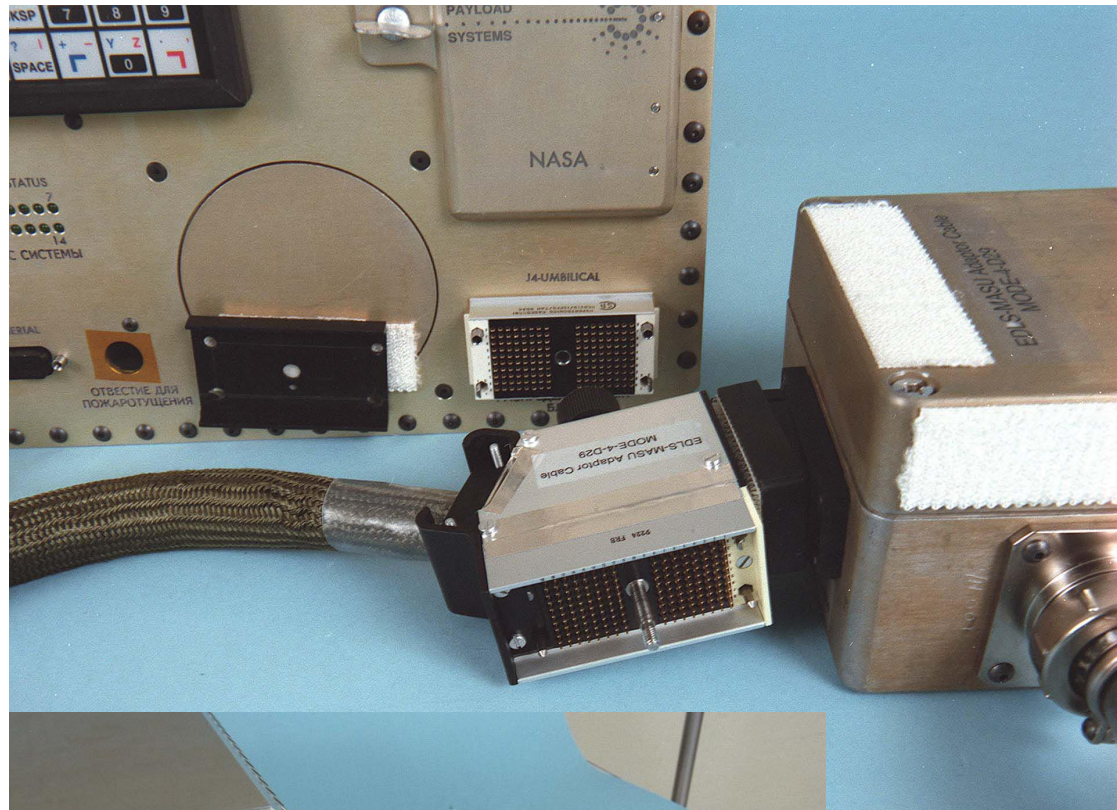

S96-18442
Figure ISS-20 Cable End Connection to MiSDE/MASU

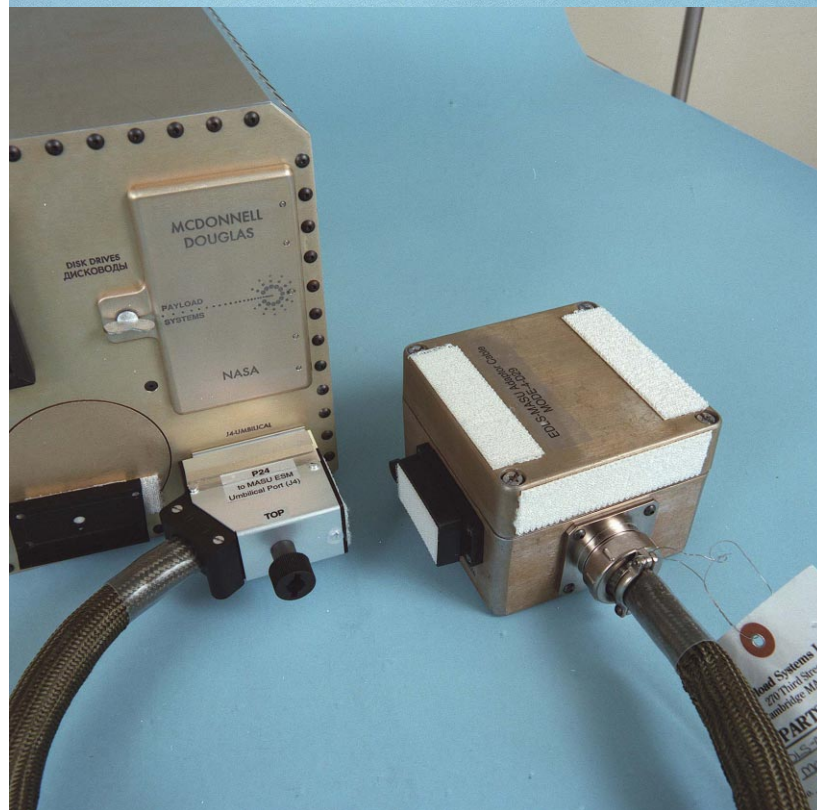

S96-18443
Figure ISS-19 EDLS/MASU Adapter Cable Attached to the MiSDE/MASU



S96-18439
Figure ISS-23 EDLS/MASU Adapter Cable



S96-18441
Figure ISS-22 Connector to the EDLS Umbilical

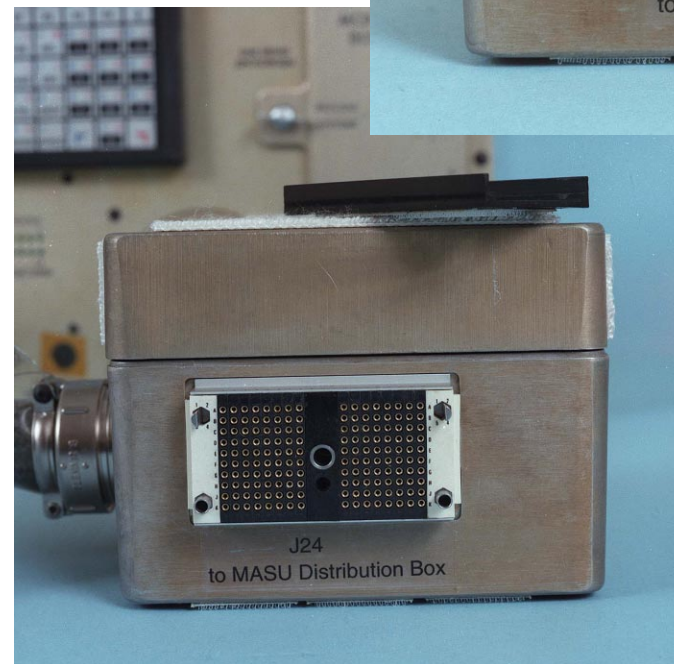

S96-18440
Figure ISS-21 Connector to MASU Distribution Box

allows synchronization of data acquisition from MiSDE and EDLS sensors.

SCIENCE OBJECTIVES

- Measure the magnitude and frequency of the crew-induced disturbances to Mir microgravity environment.
- Provide longer term data from crewmembers with more on-orbit experience.
- Qualify the variation of loads with time (learning curve and efficiency) with respect to the experience of the crewmember.
- Use video data to correlate motions specific to each crewmember.
- Establish the transfer functions between crew motion forces and spacecraft accelerations by using data from the Space Acceleration Measurement System (SAMS) experiment.
- Develop a disturbance model to estimate the International Space Station microgravity environment; assess need for payload isolation.
- Provide magnitudes and frequency content for isolation design.



FUNCTIONAL OBJECTIVES

- Deploy Sensors.
- Turn on ESM and initiate experiment protocol at the start of each data-taking session.
- Perform time synchronization with the Mir Interface to Payload System (MIPS).
- Set up video recording as necessary.
- Proceed through normal daily routines using Sensors as any other surface in Mir.
- At determined intervals, perform prescribed motions using sensors.
- Change out data disks as needed.
- Power down ESM at the end of each session.
- Stow Sensors at the end of the mission.

The MIPS-2 is located in the Core Module of the Mir Operating System. It consists of an Input/Output Controller box, portable laptop computer, and optical disk storage unit. The system is placed where needed using Velcro for attachment.

The ESM receives a time synchronization signal from the MIPS-2C at the start of each data-recording session and then is disconnected from the MIPS. The SAMS-MiSDE/MASU experiments also receive a time signal periodically. Therefore, both SAMS and EDLS record data according to the same relative time. The force and moment data from EDLS and the acceleration data from SAMS can be compiled postmission in order to develop transfer functions.

Other hardware components are 20 Write Once Read Many (WORM) optical disks; 15 2-hour video tapes; the power cable, which connects the ESM to the PUP; a MIPS-to-ESM data cable; and ESM Adapter Cable, which connects the ESM to the MIPS in order to obtain a time synchronization signal at the start of each data-taking session. *



Figure ISS-26 EDLS Umbilical Cable S96-00122



Figure ISS-24 EDLS PCMCIA Cards

S96-18497

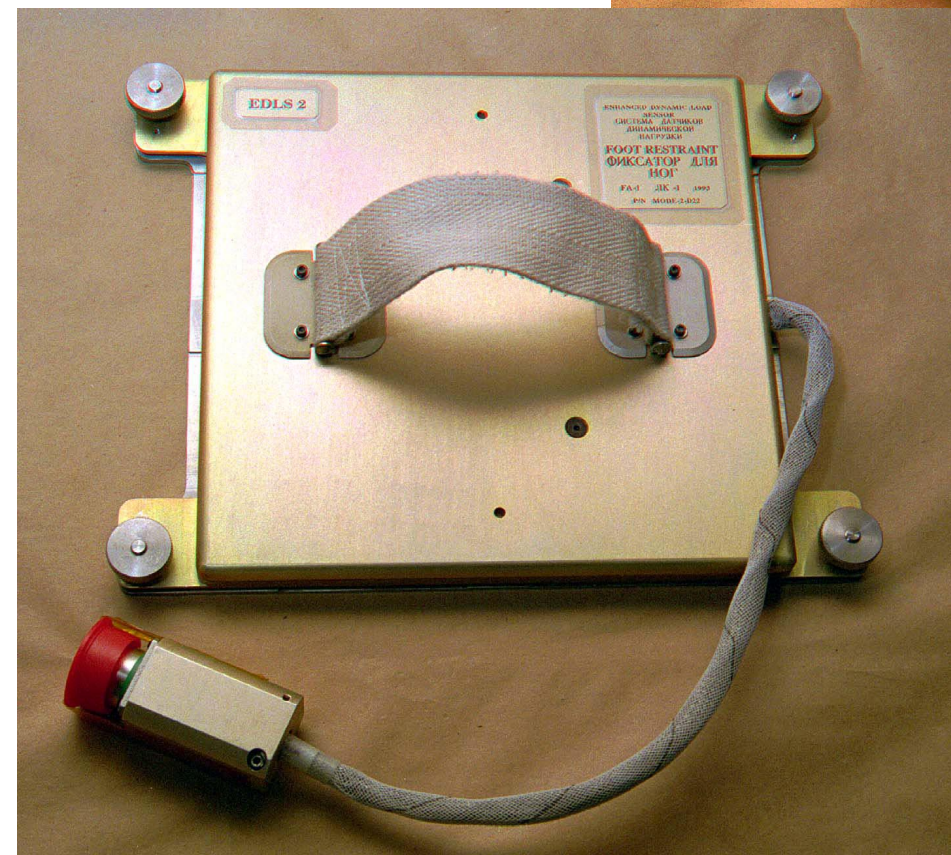

Figure ISS-25 EDLS Foothold

S96-00124



MIR STRUCTURAL DYNAMICS EXPERIMENT (MiSDE)

HARDWARE DESCRIPTION

Structural responses (primarily acceleration) and input forces for the MiSDE test events will be measured and recorded with a combination of existing and temporarily installed new instrumentation. This instrumentation consists of:

- MASU (Mir Auxiliary Sensor Unit)
- Mir Structural Dynamic Measurement System (SDMS):
 - The SDMS is existing Mir instrumentation with 22 fixed accelerometers managed by Russia/S. Mezhin.
- Mir Microgravity Measurement System (MGMS):
 - The MGMS is existing Mir instrumentation with 12 portable accelerometers managed by Russia.

EXPERIMENT DESCRIPTION

The MiSDE experiment will measure structural dynamic response data on the Mir during normal operational events using existing Mir Space Station instrumentation and new experiment unique instrumentation. The MiSDE experiment will utilize the SAMS, if available. The MiSDE hardware, defined as Mir Auxiliary Sensor Unit (MASU), consists of an Experiment Support Module (ESM), a distribution box (DB), Accelerometer Heads (AHs), and associated cables. Five triaxial and four uniaxial AHs are connected through the DB to the ESM which provides signal conditioning, data processing, and data stowage.

SCIENCE OBJECTIVES

The overall objective is to obtain data that will be used in the development of verified capability to perform structural dynamic analysis of the International Space Station (ISS). The data will be used to reduce uncertainty factors and mitigate risk in the ISS design and operation by verifying structural forcing functions, dynamic models, and structural loads of the ISS. This data will also provide critical information for determining microgravity characteristics and control/structure interaction.

FUNCTIONAL OBJECTIVES

The MiSDE flight tests consist of excitation of the Mir Space Station structure, measurement of forcing functions and structural responses, recording the data, and Post-test analyses. Test events may include Mir thruster firings, Progress docking events, IVA and EVA events, and ambient noise measured by the MASU and other existing instrumentation.

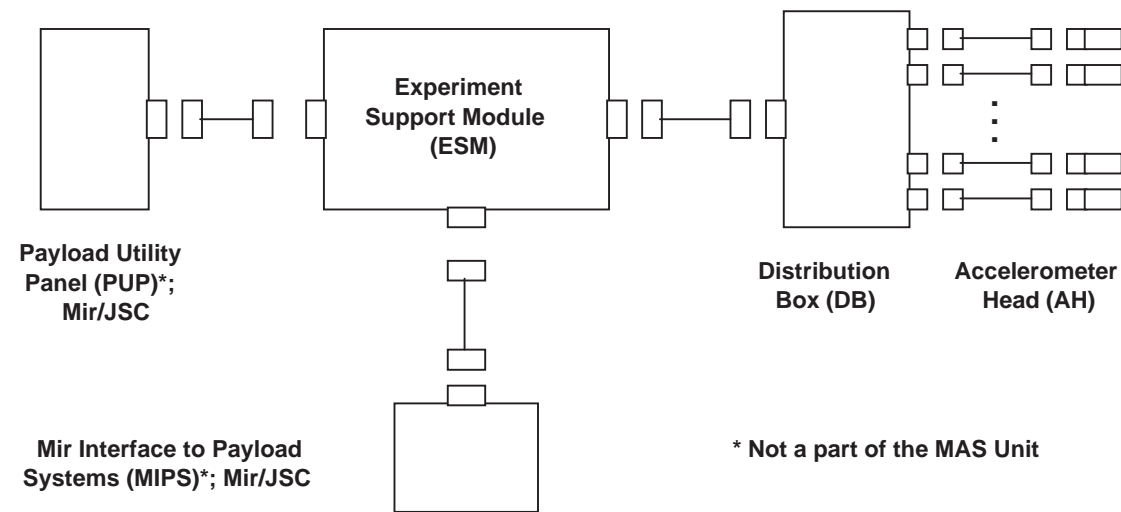

Figure ISS-28 Layout of the MASU

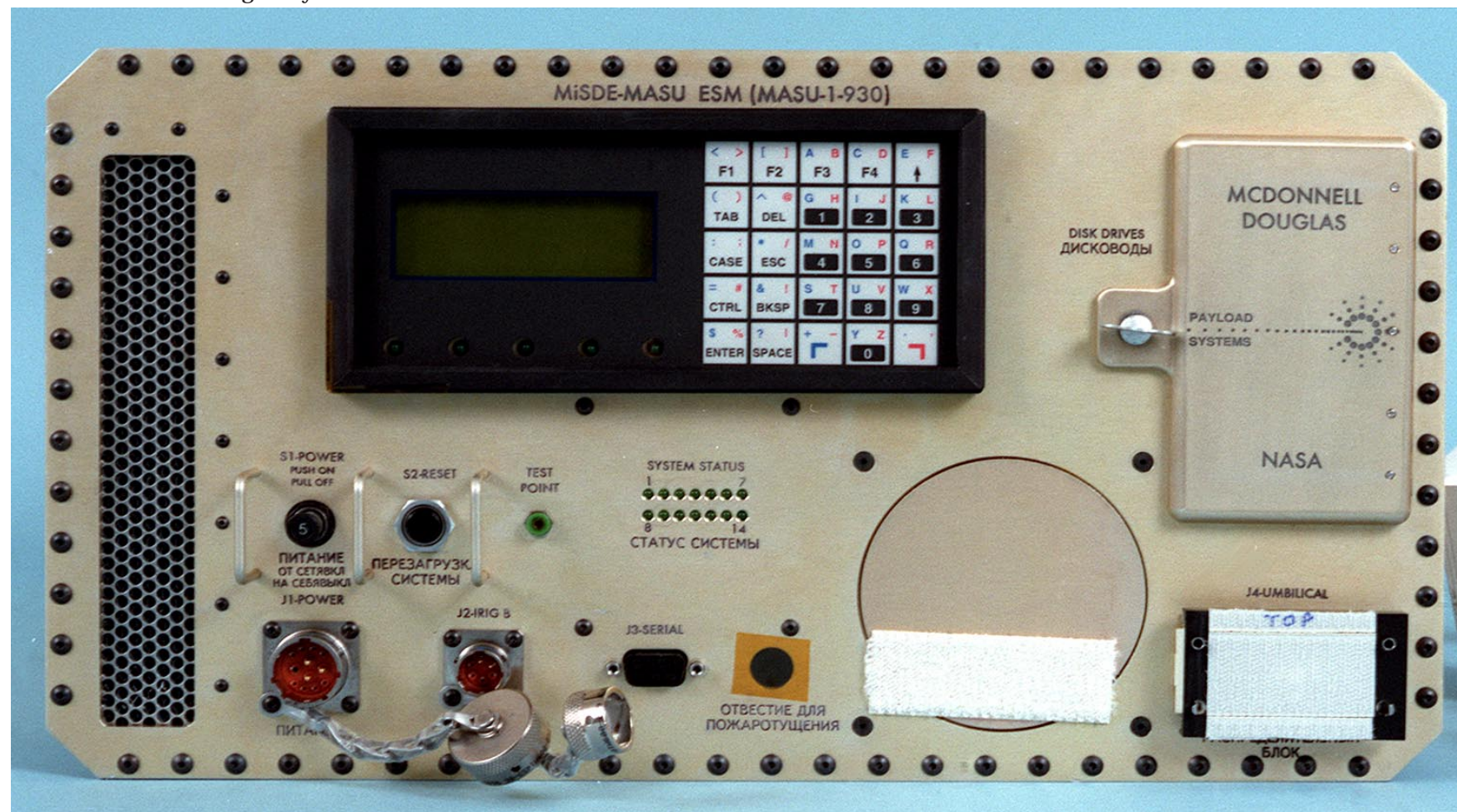

Figure ISS-27 ESM Front Face

S96-18445



Mir Structural Dynamics Experiment (MiSDE)

Principal Investigator:
 Hyoung-Man Kim, Ph.D.
 Boeing
 Manager, Engineering
 (281) 244-4306

- The following system in Mir will be used as available:
 - SAMS/Lewis Research Center
- The following Mir ancillary data will be used as available:
 - Attitude
 - Temperature
 - Humidity
 - Time
 - Thruster firing input command data
 - Inertial Measurement Unit data
 - Video camera data
 - Shuttle/Mir Docking information
- The following systems/data from the Space Shuttle will be used as available:
 - Photogrammetric Appendage Structural Dynamics Experiment/LaRC
 - Docking Force Measurement Unit/JSC
 - EVA Force Measurement Unit/JSC
 - Ancillary data

dynamic ranges of response (10 micro-g to a minimum of 100 milli-g), wider frequency contents (0.01 Hz to a minimum of 100 Hz), and torsional modes. It can also store a large volume of data (1.04 GB or 45 hours of data with 100 Hz sampling rate).

The MASU will be used to obtain dynamic response data from the Mir Space Station. It consists of an ESM, a DB, AHs, and associated cables. See Table ISS.3 for a listing of the payload system deliverables. The basic functions of the MASU will be:

- Acquire multiple channels of acceleration signals by AHs.
- Process and store acceleration data in a digital format by the ESM.
- Synchronize the ESM time using the MIPS.
- Supply the ESM power using the Payload Utility Panel (PUP).
- Store large volumes of data in a portable unit.
- Support different test events by various ESM setups.

MASU

The MASU is new MiSDE instrumentation with 8 (with 1 Uniaxial Head lost in Spektr) portable accelerometers supplied by United States/MDA for use on Increment 6. It can measure large

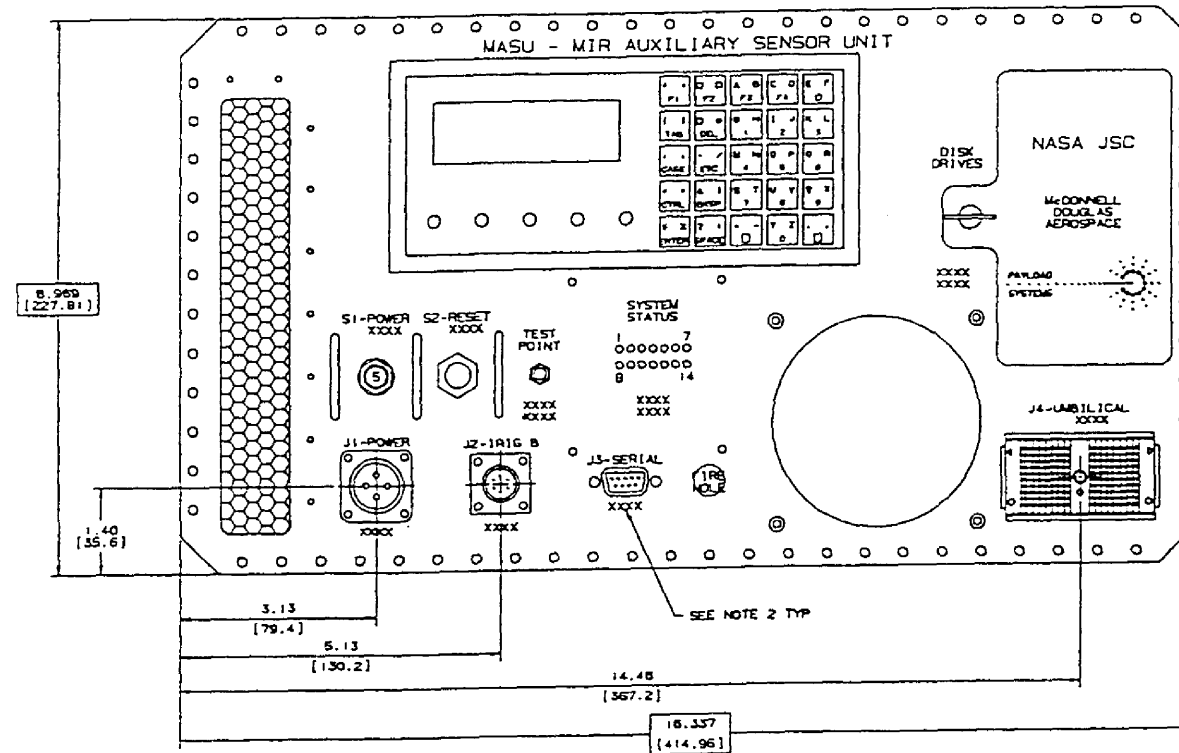

Figure ISS-30 ESM Front Panel

TABLE ISS.3
PAYLOAD SYSTEMS DELIVERABLES

NAME	PART NUMBER	QTY
MASU Experiment Support Module (ESM)	MASU-1-930	1
MASU Distribution Box (DB)	MASU-1-923	1
MASU Accelerometer Head (AH)	MASU-1-911A~D MASU-1-912A~E	8
MASU AH Cable	MASU-1-927A~D MASU-1-928A~F	10
MASU PCMCIA Disk w/ Pouch	MASU-1-990-1~8	8
MASU AH Transfer Tape	MASU-1-919-1	1 roll
MASU AH Wax	MASU-1-919-2	9 rolls
MASU AH Mounting Bracket	MASU-1-919	9
MASU AH Gray Tape	MASU-1-919-3	2 rolls
MASU Cable Tie Downs	MASU-1-929-1	1 bag
MASU Velcro	MASU-1-929-2	1 bag
PUP Cable Adapter	SEM46114416-301	1
Cable Cutter with Pouch	528-20145-30	2
Cable Label with Cable Tie	SK960513JCD-1	20/40

MASU EXPERIMENT SUPPORT MODULE

P/N: MASU-1-930
Qty: 1
Mass: 20.25 kg
Power: 105W
x, y, z: 41.40 x 22.80 x 49.00 cm
Loc: Priroda

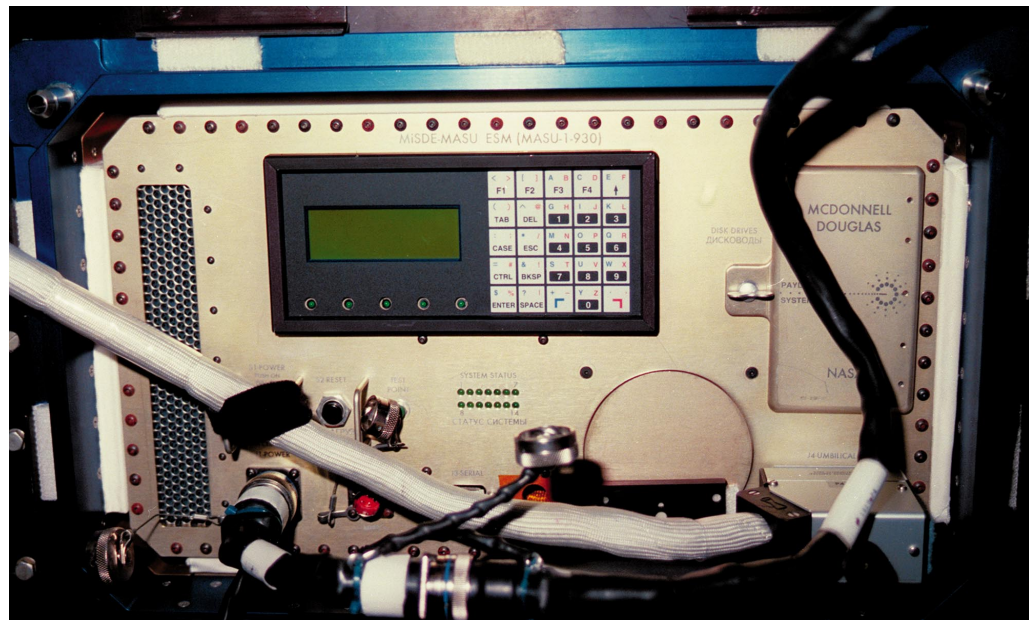

NM23-109-25

Figure ISS-29 ESM Front Face in Priroda Stowage Locker

ESM

The ESM is a single-locker sized module that provides power conversion, signal conditioning, analog-to-digital conversion, computer, and data storage for the MASU. The ESM is contained inside a single SpaceHab locker in the SpaceHab module of the U.S. Space Shuttle on its launch to Mir. It will be transferred to Mir by the crew to a Priroda locker.

Electronic circuit cards in the ESM are generally divided into two groups: the Computer System and the Signal Conditioning System. Each of the systems resides in a dedicated card cage. A fan and baffle provide active cooling inside the ESM. The ESM also contains input power safety switching circuits in the form of thermostats, airflow sensors, and relays.

The ESM remains in its locker for operations. The crew interface with the ESM is on the ESM front panel and may be accessed by opening the locker door. Scientific data taken during the experiments will be stored in the ESM using Personal Computer Memory Card International Association (PCMCIA) removable hard disks.

These are compact, "credit card" sized hard disks, which were returned to the ground for analysis. The ESM provides two PCMCIA disk readers so that each hard disk may be backed up.

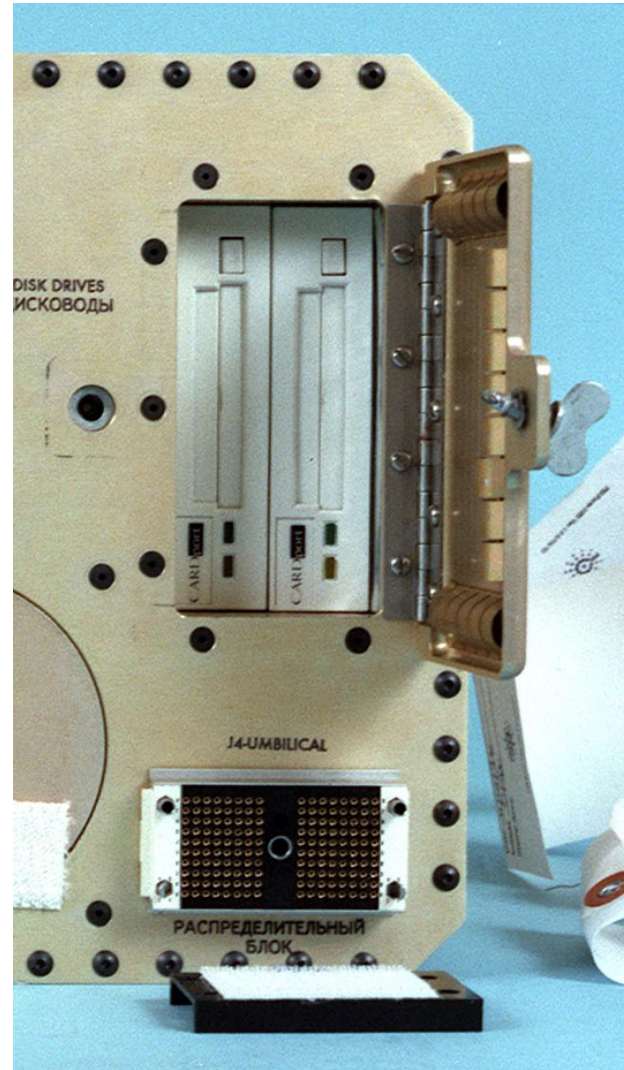

Figure ISS-32 S96-18447
Data Disk Location on Front Face of ESM

The front panel of the ESM provides a port for the DB umbilical cable, a backlit Liquid Crystal Display (LCD) and a keypad for crew interface, a test point for testing chassis ground, a port for the MIPS-to-ESM data cable, and two disk readers for the PCMCIA hard disks.

DB

The DB is an aluminum box that receives signals from all nine AHs and routes them to the umbilical cable, which returns them to the ESM. One circular connector is associated with each AH, and one spare is provided. The umbilical connector is a zero insertion force connector,

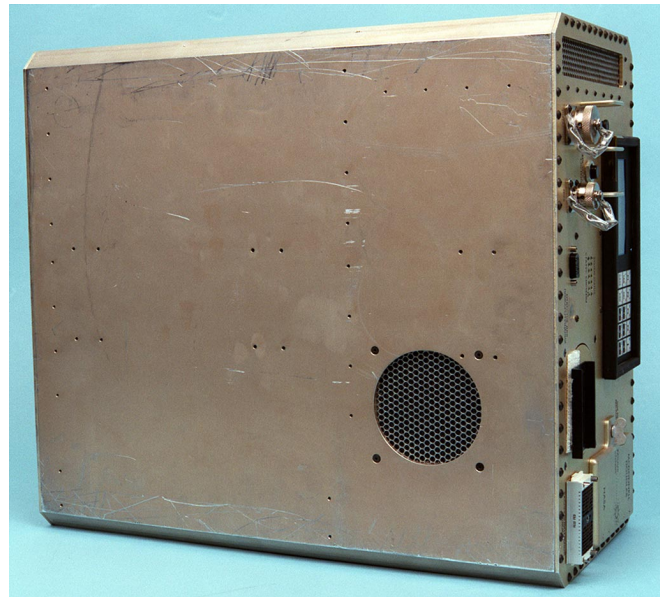

Figure ISS-31 S97-01053
ESM Bottom Panel

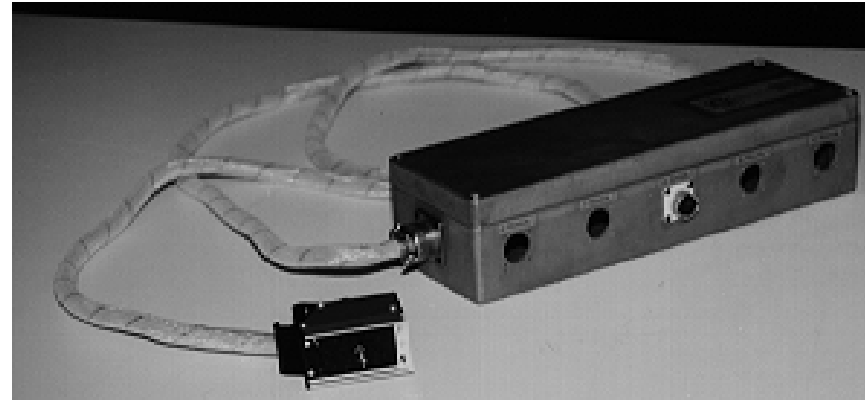

Figure ISS-33 DB and Cable (Training)

similar to the umbilical connector used in the EDLS payload. Sensor power for the accelerometers (+/- 15 Vdc) is also routed through the DB.

The DB is a passive element. It contains wiring and connectors only.

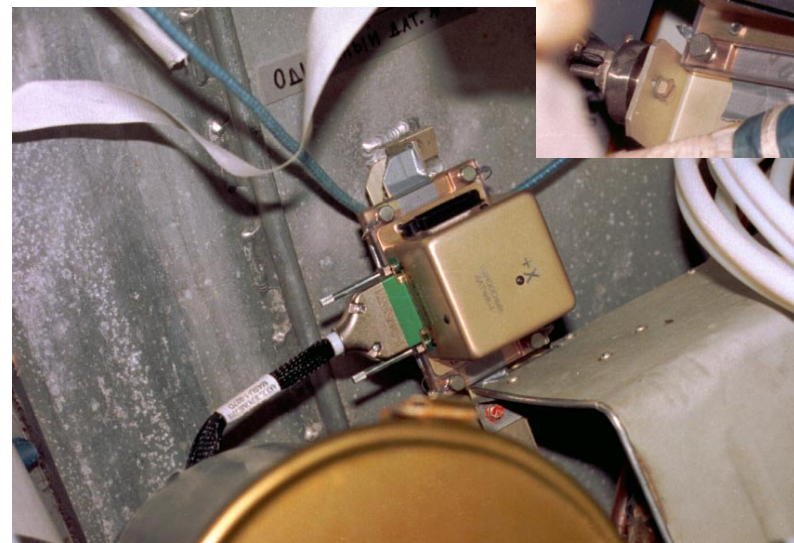

Figure ISS-34 NM22-250-17
Acceleration Head Installed on Mir



Figure ISS-35 NM22-250-21
Acceleration Head Installed on Mir



The experiment data and analysis results will benefit the design and operation of the International Space Station by providing critical information for the verification of structural responses and analytical models.

The MiSDE will also use the existing instrumentation such as Space Acceleration Measurement System (SAMS), Enhanced Dynamic Loads Sensor (EDLS), and Photogrammetric Appendage Structural Dynamics Experiment (PASDE). Ancillary data such as temperature, thruster firing input command data, Inertial Measurement Unit (IMU) data, and video camera data will also be used for experiment data processing and analysis.

The MASU measures and records accelerations from nine pre-planned locations in the Mir Space Station. It receives power from the Payload Utility Panel (PUP) and also connects with the Mir Interface to Payload System (MIPS) periodically to receive a time signal.

The MASU can measure large dynamic ranges of response (10 micro-g to a minimum of 100 milli-g), and wider frequency contents (0.01 Hz to a

minimum of 100 Hz). It can also store a large volume of data (1.04 Giga-Byte or 45 hours of data with 100 Hz sampling rate.)

The MASU consists primarily of an Experiment Support Module (ESM), a Distribution Box (DB), and nine Accelerometer Heads (AHs) supplied by McDonnell Douglas Aerospace.

AHS

Two types of AHs will be flown. There are four uniaxial units and five triaxial units. The only difference between these two types is the number of accelerometers installed inside the aluminum housing. Temperature output is available on each sensor. One temperature from each AH will also be included in the data recorded for MASU.

The sensors are mounted on an aluminum triaxial mount and wired to a 25-pin D-subminiature connector. An iridited aluminum cover is secured over the triaxial mount, which prevents direct crew contact with the sensor or wiring and provides Electromagnetic Interference

shielding. A layer of fiberglass circuit board material is secured to the underside of the AH to help isolate it from temperature variations on the Mir surfaces to which they are attached.

The base of the AH is designed to permit several mounting methods for attachment of the AHs to the Mir structure: adhesive transfer tape or beeswax; and a bracket-and-gray-tape option, used if the previous option proves inadequate. The transfer tape or beeswax will be applied to the AH bottom before flight with a removable liner protecting the bonding surface. Once on orbit, the liner is removed and the AH is pressed against the desired mounting surface. Several transfer tape candidates have been identified. Beeswax is routinely used in acceleration measurement applications on the ground and has the benefit of ease if it must be moved to alternate locations if the background acceleration levels or other operational factors demand. The bracket-and-gray-tape option is similar to the method used for attachment of the EDLS experiment hand-holds, foot loops, and push pads to the Orbiter middeck surfaces during STS-62. With this method, an aluminum bracket is secured to the base surface using gray tape. Several knurled cap screws permit the use of such brackets as well as the adhesive approaches described previously.

The AH converts physical accelerations into electrical signals, including five triaxial AHs and four uni-axial AHs (a total of 19 accelerometers), which will be distributed throughout the Mir Space Station. Figure ISS-37 shows the portable AH locations that will allow the measurement of torsional modes as well as bending and axial modes. The DB connects all the acceleration

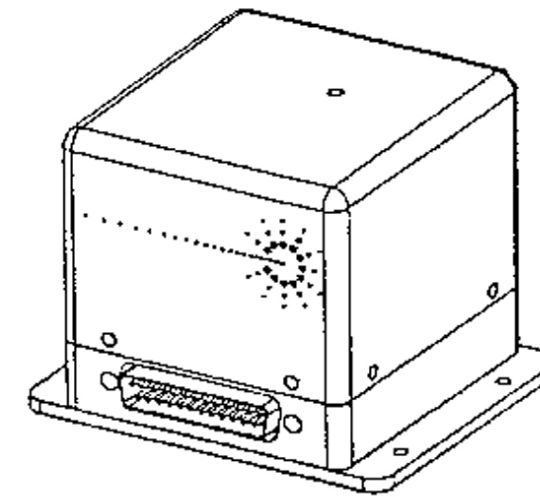

Figure ISS-38 MASU AH

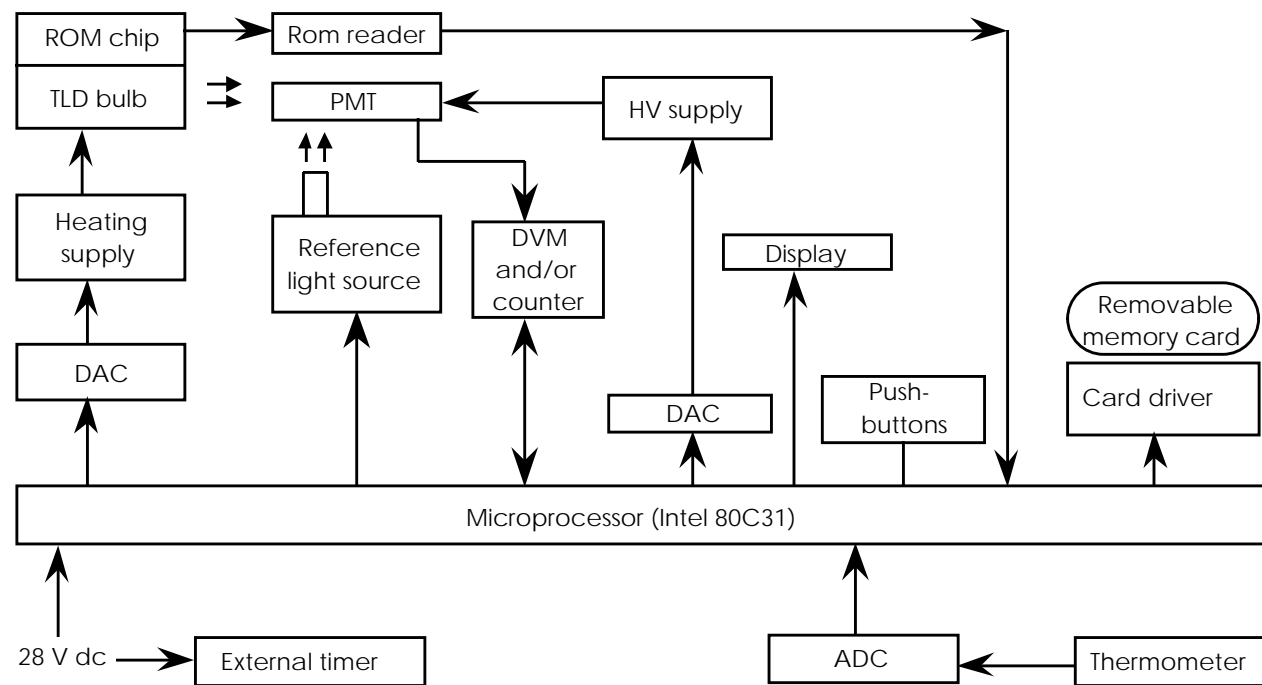

Figure ISS-36 Simplified Block Diagram

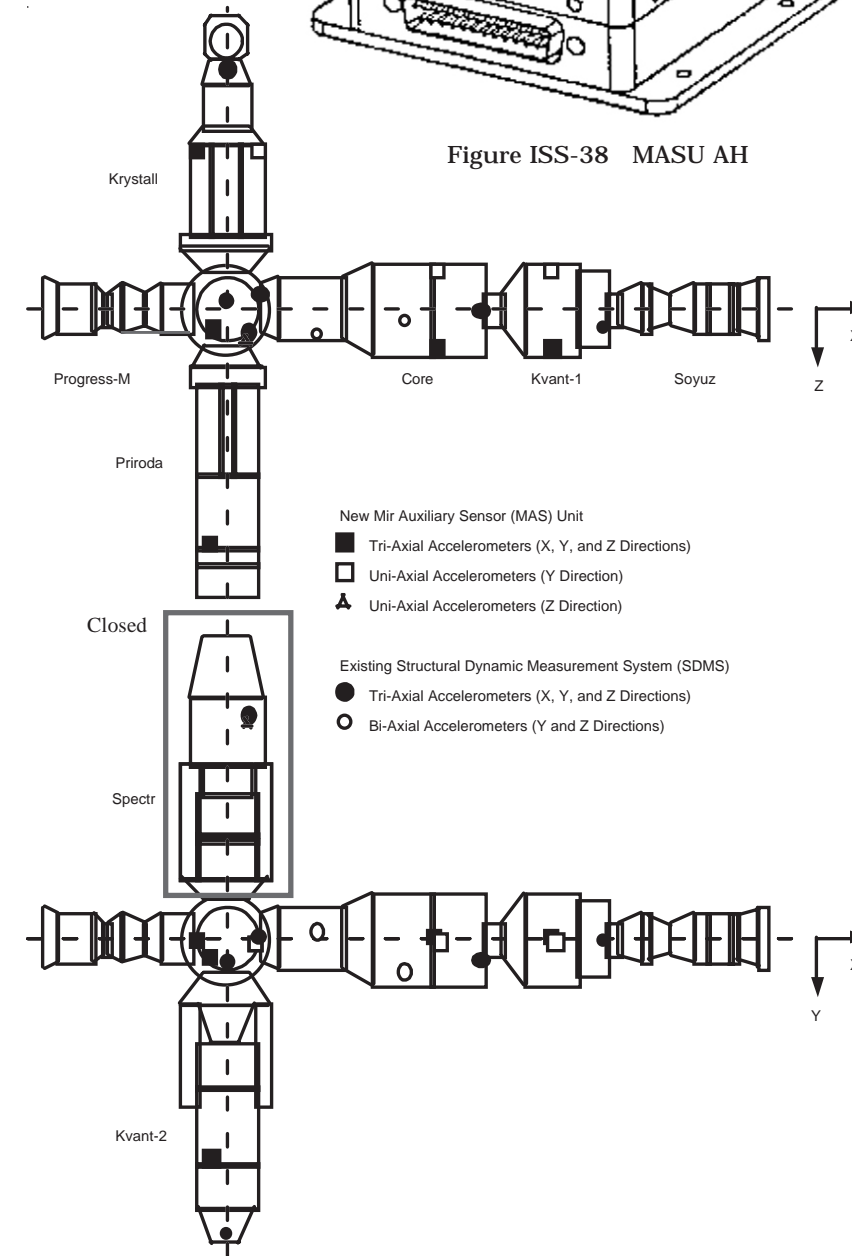

Figure ISS-37 MASU Sensor Locations



signals to the ESM, which processes and stores the data in a digital format. It is noted that the design of the MiSDE ESM is very similar to the EDLS ESM, which will be manufactured by the same company.

High-fidelity electromechanical servo-accelerometers and the variable sampling rate up to 500 Hz will be used to accurately measure wider frequency contents of 0.01 Hz to a minimum of 100 Hz. The MASU is designed to provide the maximum range of 100 milli-g and an end-to-end accuracy of 10 micro-g (at maximum), which is a difference between the measured data and real/physical acceleration. The ESM will also process and record temperature signals from accelerometers to compensate thermal bias, if necessary, in the postflight data analysis.

The ESM setup including gain selection will normally be configured automatically using preloaded information (called a parameter file) on the hard disk, but automatically-loaded setups can be modified manually to change sampling rate, filter rolloff frequency, and channel gains (one channel at a time). ESM time will be synchronized by the MIPS. Test data will be stored on the 260 MB removable PCMCIA hard disk, which weighs 2.3 ounces and resembles a (0.4 inch thick) credit card. Eight hard disks, four primary and four backup disks, will store over 1.04 GB of data, equivalent to 45 hours of data with 100 Hz sampling rate.

Power will be supplied by the PUP and the power supply voltage will be +27 +/- 5 Vdc nominal. Power consumption will be approximately 85 watts and each test event lasts 30 to 60 minutes less setup time. A total weight of the MASU will be 216 pounds maximum and a volume will be equivalent to four SpaceHab (or Space Shuttle middeck) lockers. The MASU was developed as equivalent to Space Shuttle Class D payloads. *

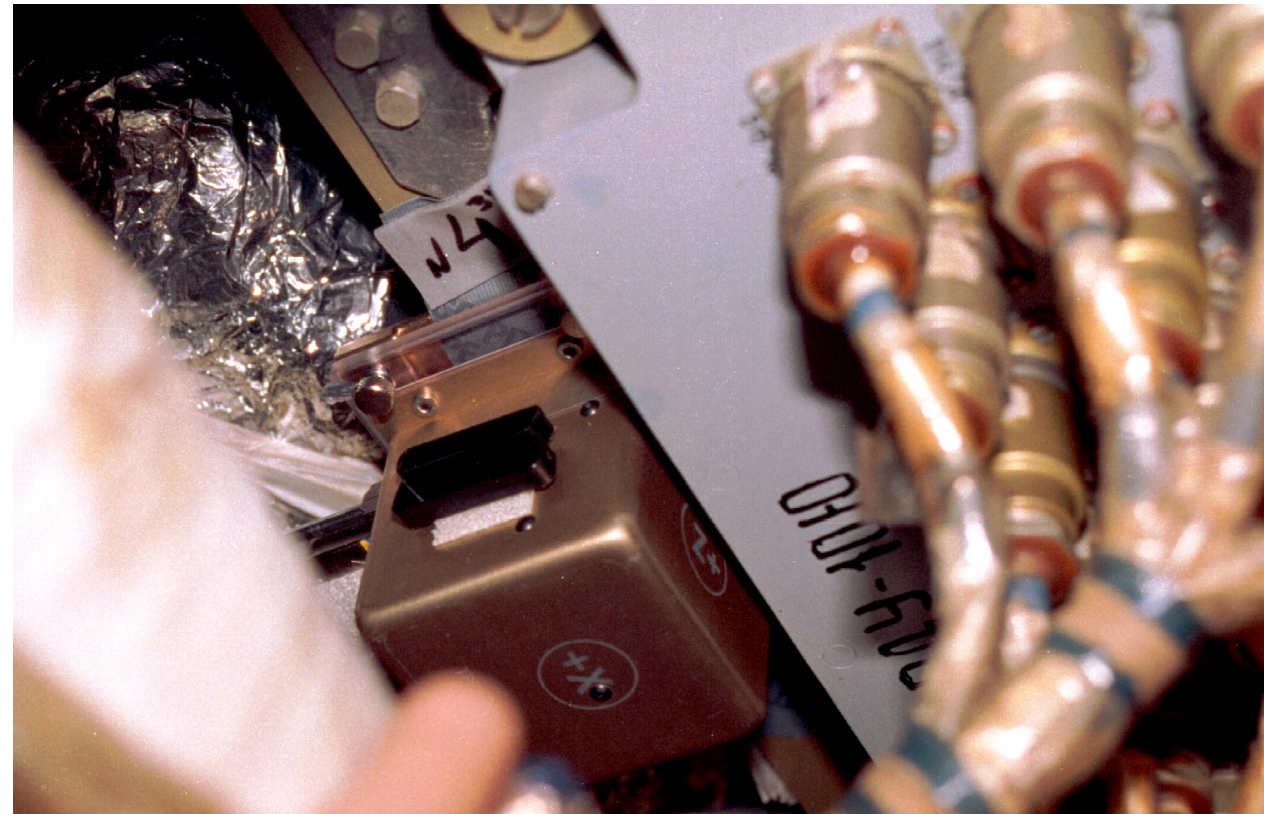

Figure ISS-40 AH Installed On-Orbit

NM22-250-24

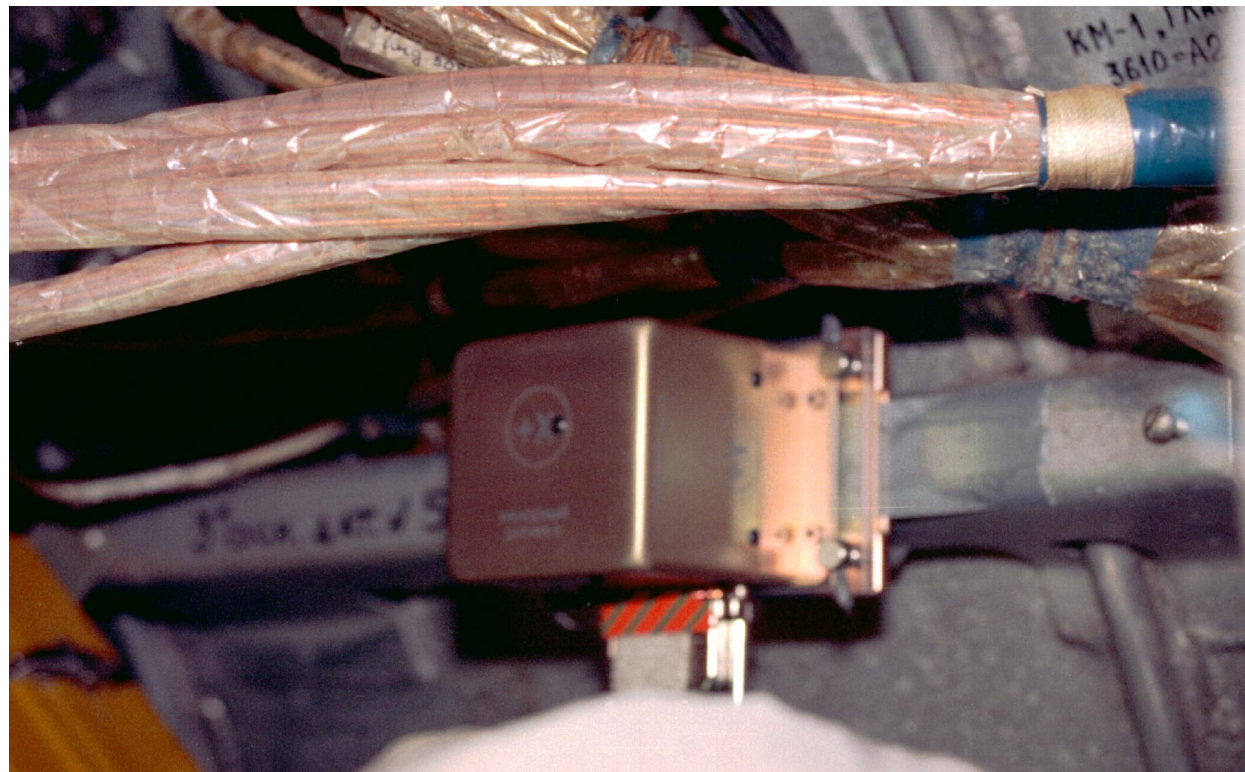

Figure ISS-39 AH Installed On-Orbit

NM22-250-18

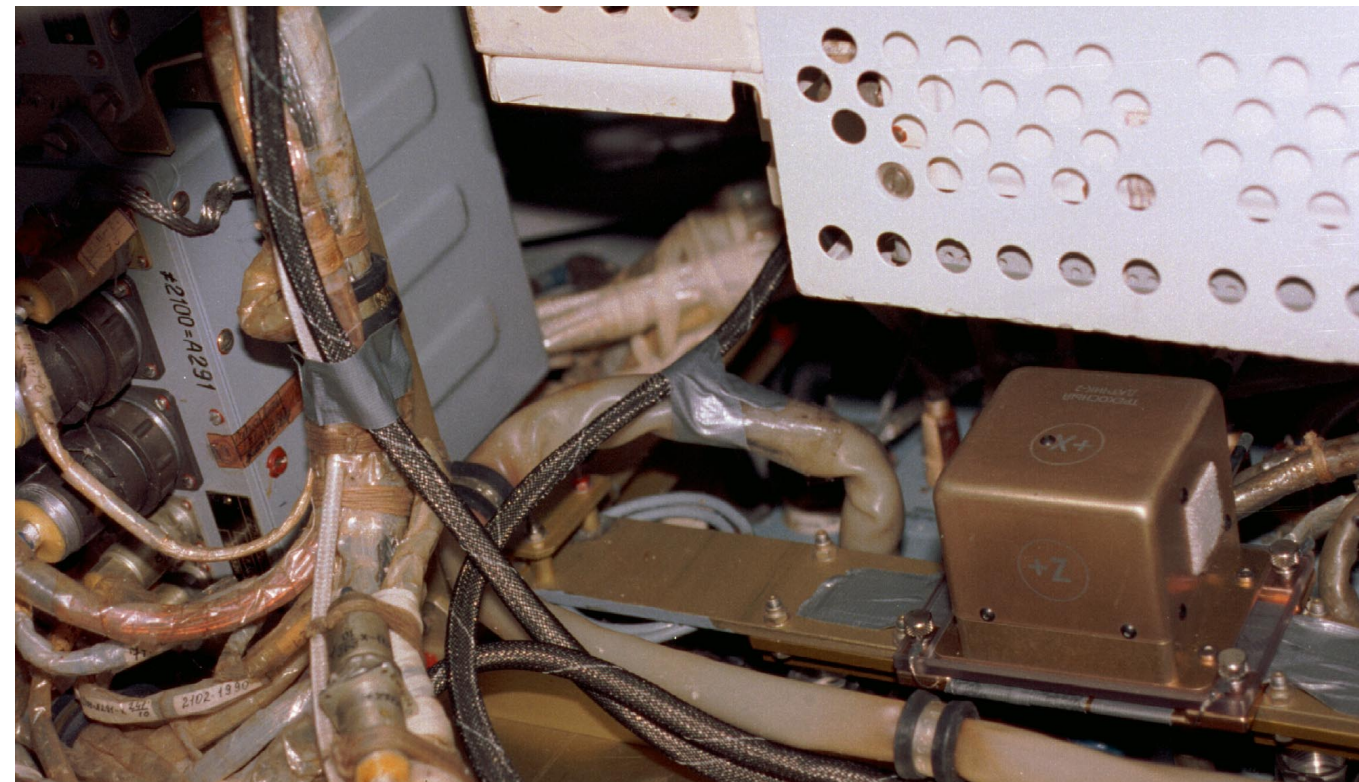

Figure ISS-41 AH Installed On-Orbit

NM22-250-08

MASU ACCELEROMETER HEADS TRIAXIAL

P/N: MASU-1-912A THRU E
 Qty: 5 (1 Lost on Spektr)
 Mass: 0.66 kg
 Power: 0
 x, y, z: 7.10 x 7.40 x 9.40 cm

MASU ACCELEROMETER HEADS UNIAXIAL

P/N: MASU-1-911A THRU D
 Qty: 4
 Mass: 0.66 kg
 Power: 0
 x, y, z: 7.10 x 7.40 x 9.40 cm



OPTICAL PROPERTIES MONITOR (OPM)

EXPERIMENT DESCRIPTION

The OPM will expose materials to the external Mir low earth orbital environment and measure the effects of this exposure in-situ with on-board optical instruments. Environmental monitors will also measure test sample exposure to atomic oxygen, solar/earth irradiance and molecular contamination. The OPM will collect data for about 9 months and then be retrieved. Collected data from the OPM will be telemetered to ground and will be stored on disks by the Mir crew. These disks should be returned to the ground, along with the OPM.

SCIENCE OBJECTIVES

1. Determine the effects and damage mechanisms of the Mir Space Station environment on materials.
2. Provide data to validate lifetime prediction models.

The Hardware will be removed and brought down on STS-89. ✱

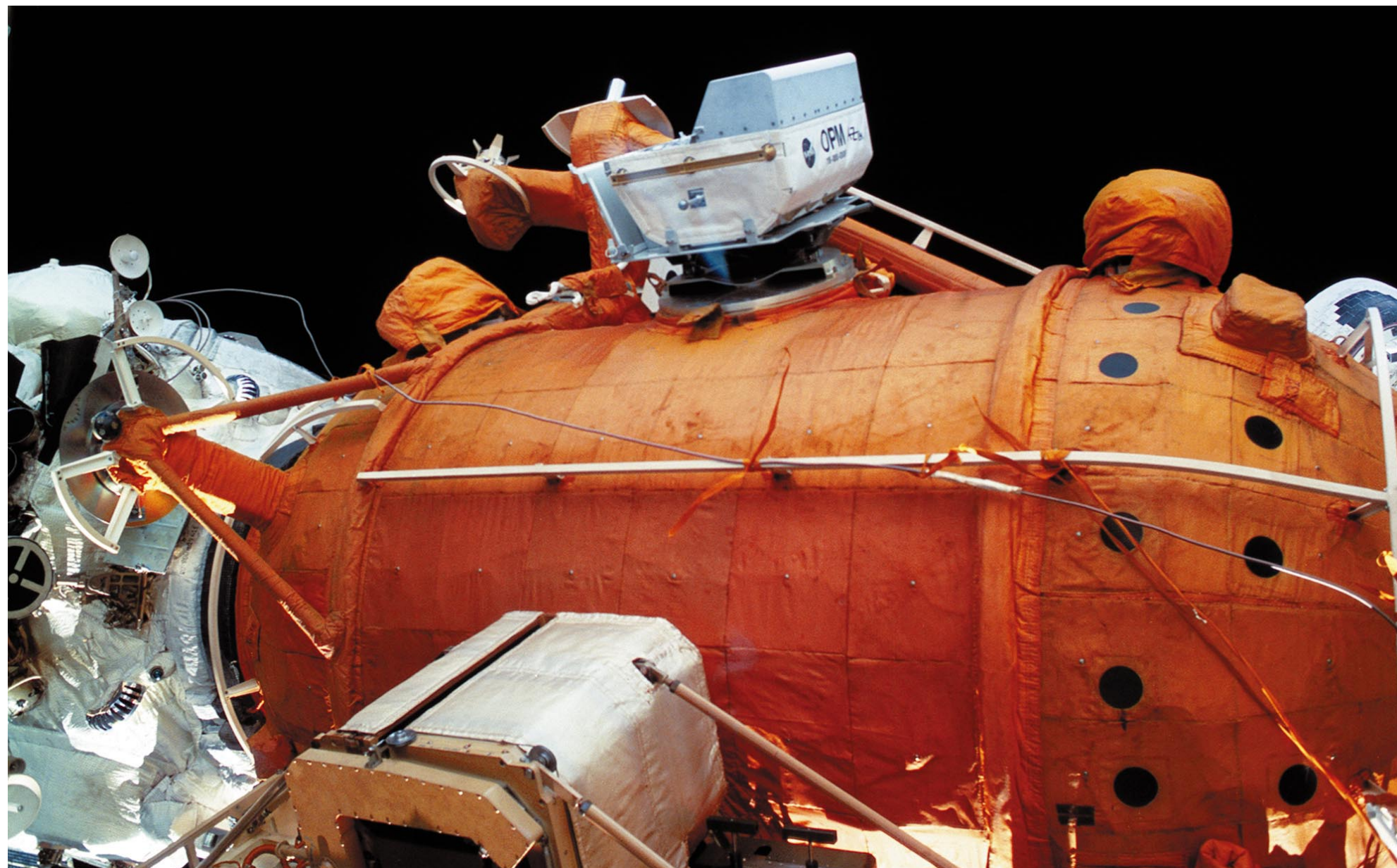

NM23-010-16

Figure ISS-42 OPM Mounted on the Docking Module

Principal Investigator:
Don Wilkes
AZ Technology
(205)837-9877 x108

Dave Cornut
(205)837-9877 x186

OPM ASSEMBLY

P/N: 118-000-000
Qty: 1
Mass: 125.00 kg
Power: 220 W
x, y, z: 82.90 x 68.30 x 52.10 cm
Loc: Kavant 1, External

OPM MIPS DISK

P/N: 118-S/W-0000
Qty: 2
Mass: 0.02 kg
Power: 0
x, y, z: N/A

OPM CABLES (WITH BAG)

P/N: 118-SE1-5000
Qty: 1
Mass: 5.99 kg
Power: 0
x, y, z: N/A



SPACE PORTABLE SPECTROREFLECTOMETER (SPSR)

EXPERIMENT DESCRIPTION

The Space Portable Spectroreflectometer provides an in-space inspection instrument for non-destructive, quantitative engineering evaluation of spacecraft exterior surfaces.

The SPSR measures total hemispherical reflectance as an identification of effects of the space environment on materials such as thermal control coatings, viewing windows, reflectors, solar power systems, etc. It will provide valuable data for determining how materials degrade when exposed to the space environment within the Shuttle/Mir implementation framework.

SCIENCE OBJECTIVES

The SPSR experiment is a technology investigation with the following objectives:

1. Determine effects and damage mechanisms of the Mir space environment materials.
2. Provide flight testing of spacecraft materials by measuring total hemispherical reflectance from 250 to 2500 nm.
3. Provide data to validate ground test facilities and prediction models for material behavior in space.
4. Develop and test a reusable flight instrument for the study of the behavior of material in the space environment.

HARDWARE DESCRIPTIONS

The major flight components of the SPSR are listed in Table ISS.4. The SPSR mainly consists of the reflectometer unit and the battery pack. Mir cosmonauts will use the assembled SPSR during EVA to measure total hemispherical reflectance of external spacecraft surfaces.

The SPSR flight software will be installed on the MIPS-2 laptop before launch. The SPSR cable will connect the MIPS-2 laptop to the SPSR for downloading reflectance data for later telemetry to the ground. While the SPSR is not in use, it shall be stowed on board the Mir in the provided flight bag.

TABLE ISS.4
EXPERIMENT FLIGHT HARDWARE

HARDWARE TITLE	QTY	PART#/SERIAL#
SPSR Reflectometer Unit	1	293-110-00
SPSR Battery Housing	1	293-150-0000
EMU Battery	1	SED13101547-308
Cables	1set	293-900-4000
Stowage Bags	1set	293-170-1000
SPSR/MIPS-2 Flight Software	1set	293-800-1000
SPSR Fuse Kit	1	293-800-2000
SPSR Flight Bag	1	293-170-2000

Battery Housing

MLI Blanket

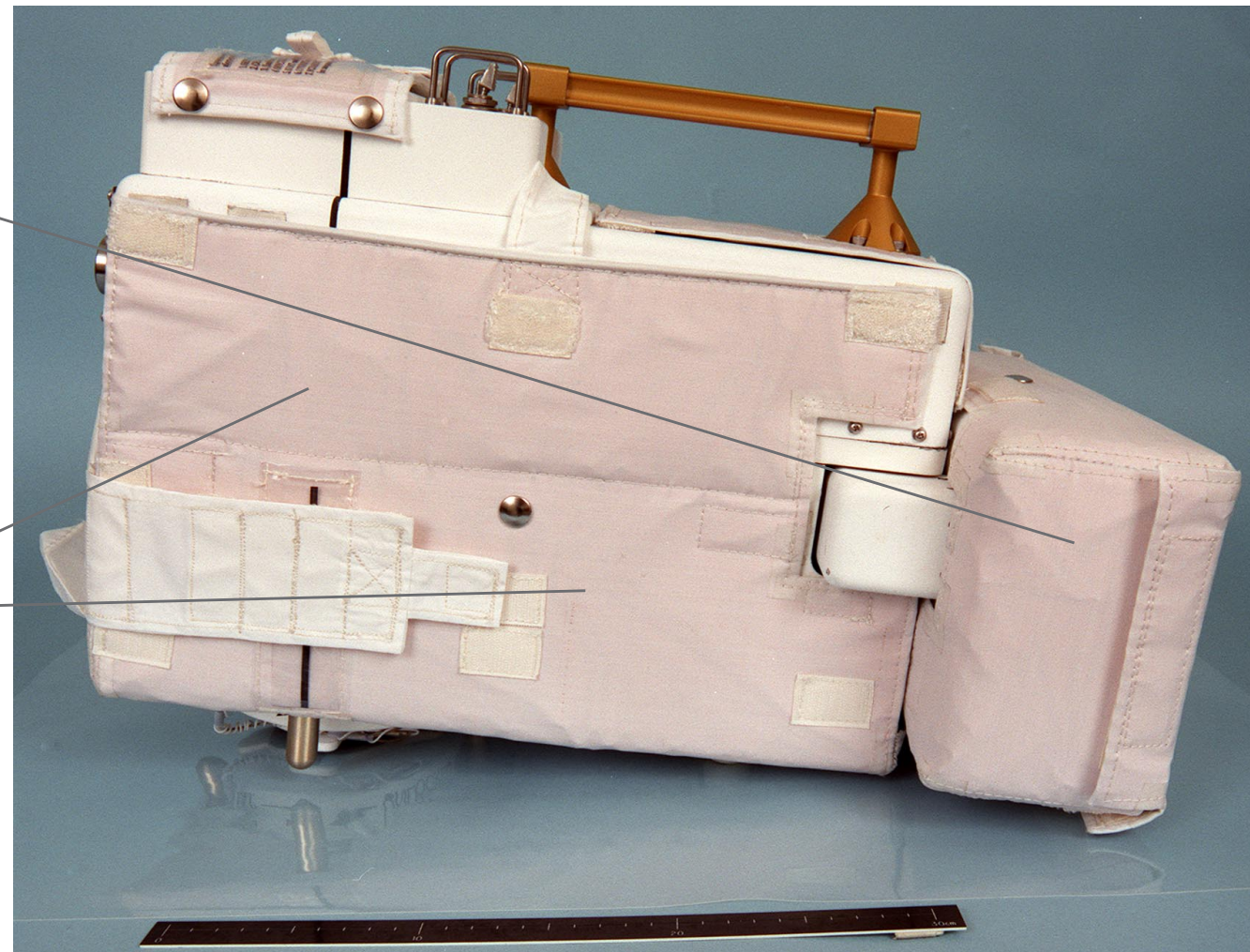

Figure ISS-43 SPSR Hardware, Side View

S97-05343

D.I.D.

Space Portable
Spectroreflectometer

Principal Investigator:
Ralph Carruth
NASA/MSFC/EH12
(205)544-7647

James Zwiener
(205)544-2528

SPSR SOFTWARE DISKETTE

P/N: 293-800-1000
Qty: 1
Mass: 0.04 kg
Power: 0
x,y,z: 9.40 x 9.10 x 0.70 cm

SPSR STOWAGE BAG

P/N: 293-170-1000
Qty: 1
Mass: 0.06 kg
Power: 0
x,y,z: 69.50 x 74.00 x 0.30 cm

SPSR DATA CABLE

P/N: 293-900-4000
Qty: 1
Mass: 0.30 kg
Power: 0
x,y,z: 152.00 x 4.10 x 1.30 cm

SPSR REFLECTOMETER UNIT

P/N: 293-110-0000
Qty: 1
Mass: 15.60 kg
Power: 0
x,y,z: 44.50 x 23.20 x 39.10 cm

SPSR

Power Consumption: N/A
Start-Up Current: N/A
OnBoard Electrical Supply:
SPSR battery pack
Insulation Resistance: N/A
Operational Life: No info
Shelf Life: No info



SPSR REFLECTOMETER UNIT

The SPSR reflectometer measures the total hemispherical reflectance of test materials over the spectral range from 250 nm to 2500 nm. The design objective for the SPSR reflectometer is to measure total hemispherical reflectance of spacecraft materials with the following performance:

- Accuracy: $\pm 3\%$
- Repeatability: $\pm 1\%$
- Wavelength range: 250 nm through 2500 nm
- Spectral resolution: better than 5% of wavelength
- Number of spectral measurements: 100 points for a full scan

The reflectometer optical bench, position indicators, and electronics are enclosed in a 3003 alloy aluminum casing 0.090 inch thick. The SPSR reflectometer is a standard optical design that is used routinely in portable spectroradiometers. Two light sources, tungsten and deuterium lamps, are used with a scanning prism monochromator with selectable slit widths to provide the monochromatic energy for the spectral measurement. A 115 mm (4.5 inch) diameter integrating sphere collects both the specularly- and diffusely-reflected light from a wall mounted sample providing the angular integrated measurement capability. A UV enhanced silicon photodiode detector and a lead sulfide detector are used with the integrating sphere to cover the required 250 nm to 2500 nm spectral range.

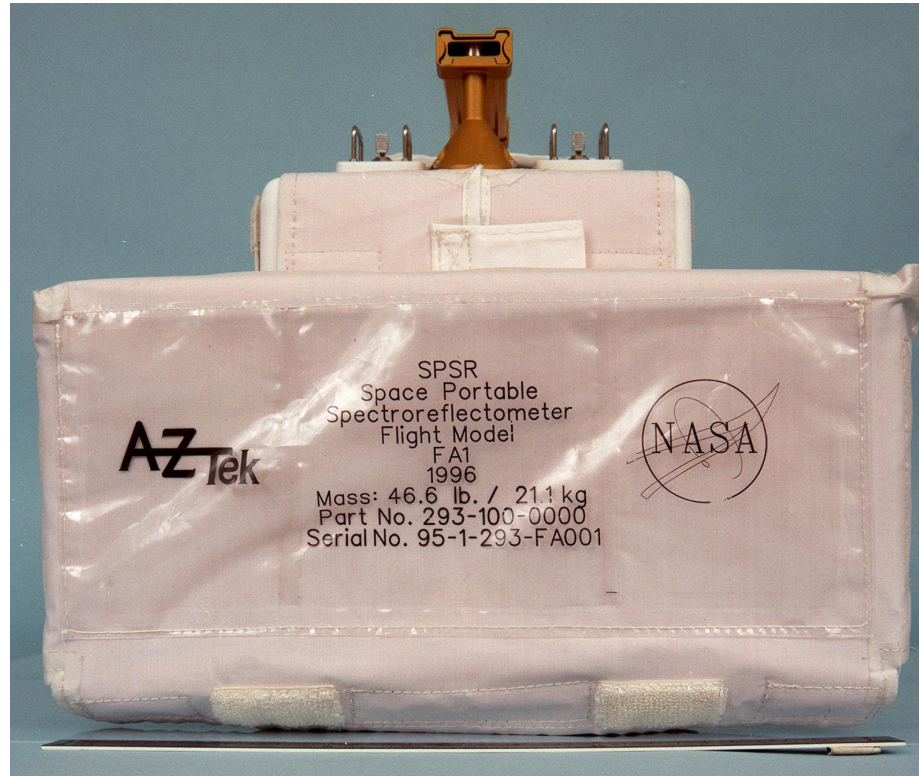

S97-05344

Figure ISS-45 SPSR Battery Housing, Rear View

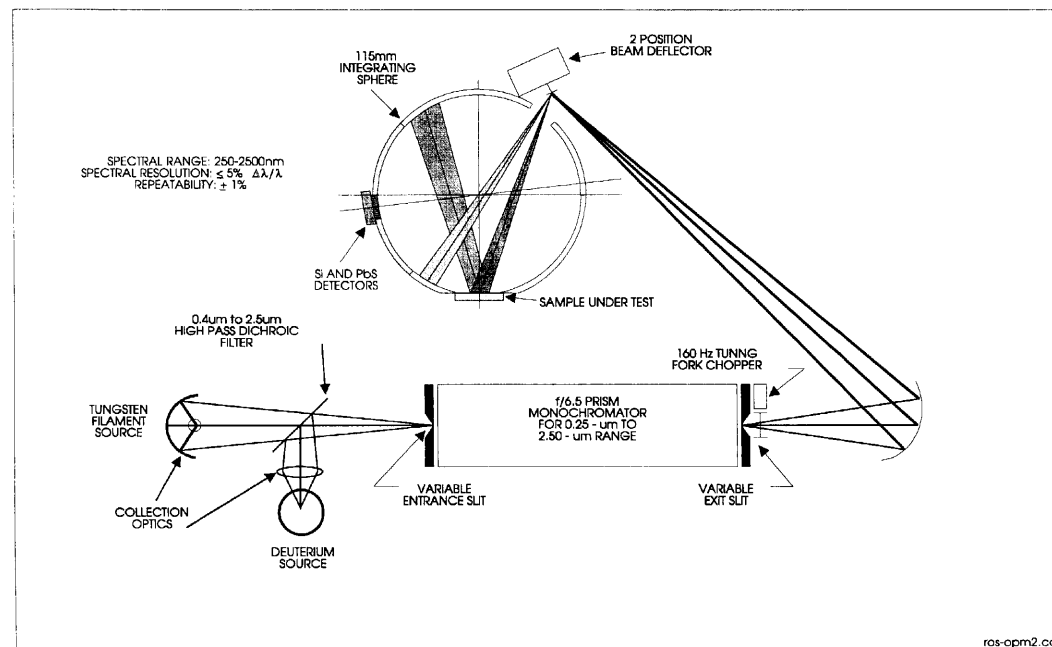

ros-opm2.cdr

Figure ISS-44 Reflectometer Optical Schematic

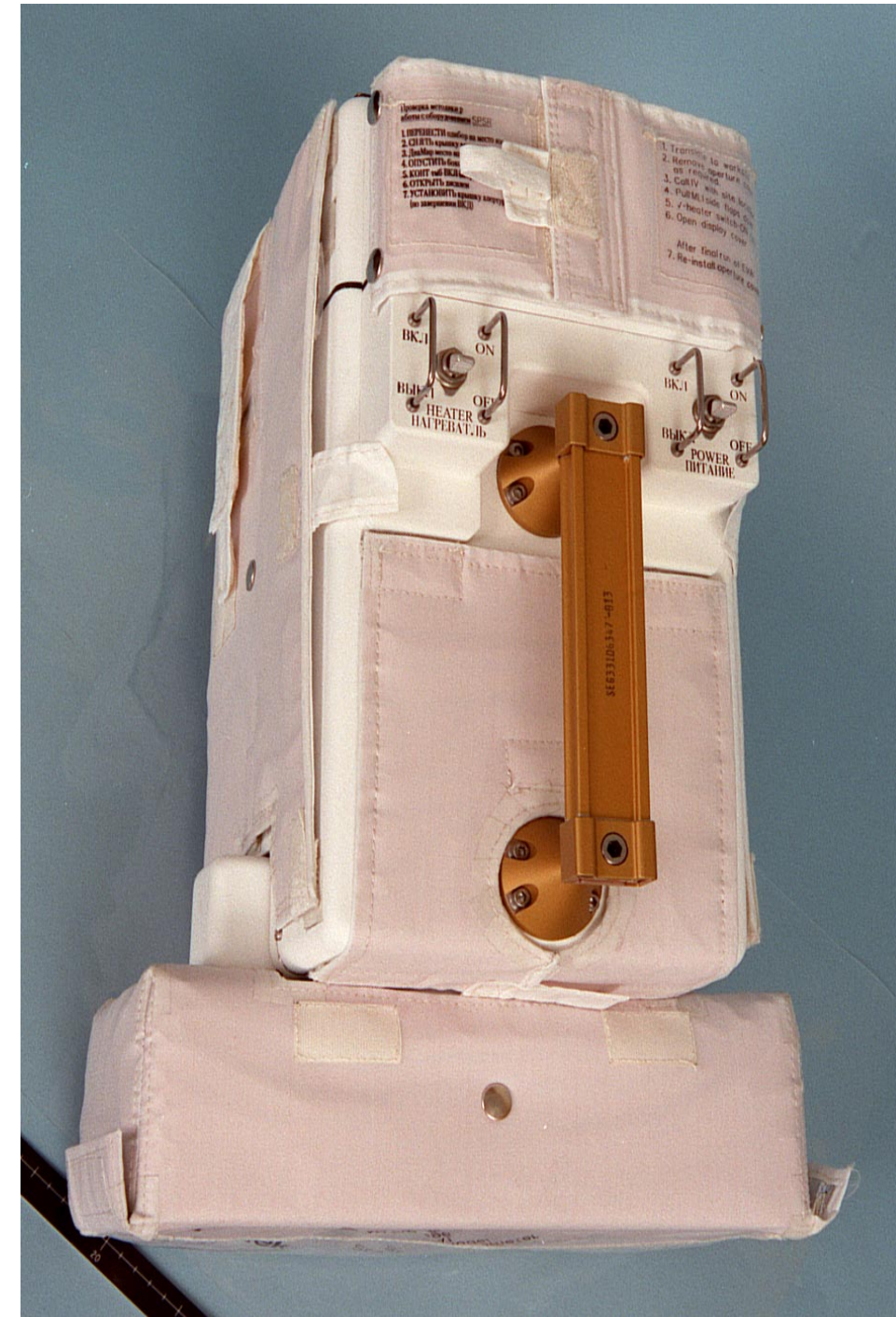

S97-05339

Figure ISS-46 SPSR Hardware and EVA Configuration, Top View



The user interface of the reflectometer unit is through a touch screen display based on the Electronic Cuff Checklist (ECC) used by NASA astronauts. The LCD display will give the astronaut or cosmonaut feedback on the unit's position relative to the surface to be measured as well as real-time reflectance data. Four position indicators on the reflectometer unit will be used for flat surfaces; curved surface measurements will require that only the front and back position indicators show full contact. The position indicators have a 1 inch travel distance, with only half that distance needed for contact with the flexible bellows. The position repeatability of the indicators selected for SPSR is 0.01%. The spring force from the position indicators will be 0.3 pounds per indicator. Data from the position indicators will be stored with the reflectance measurements.



S97-05338

Figure ISS-47 SPSR Hardware, Front View

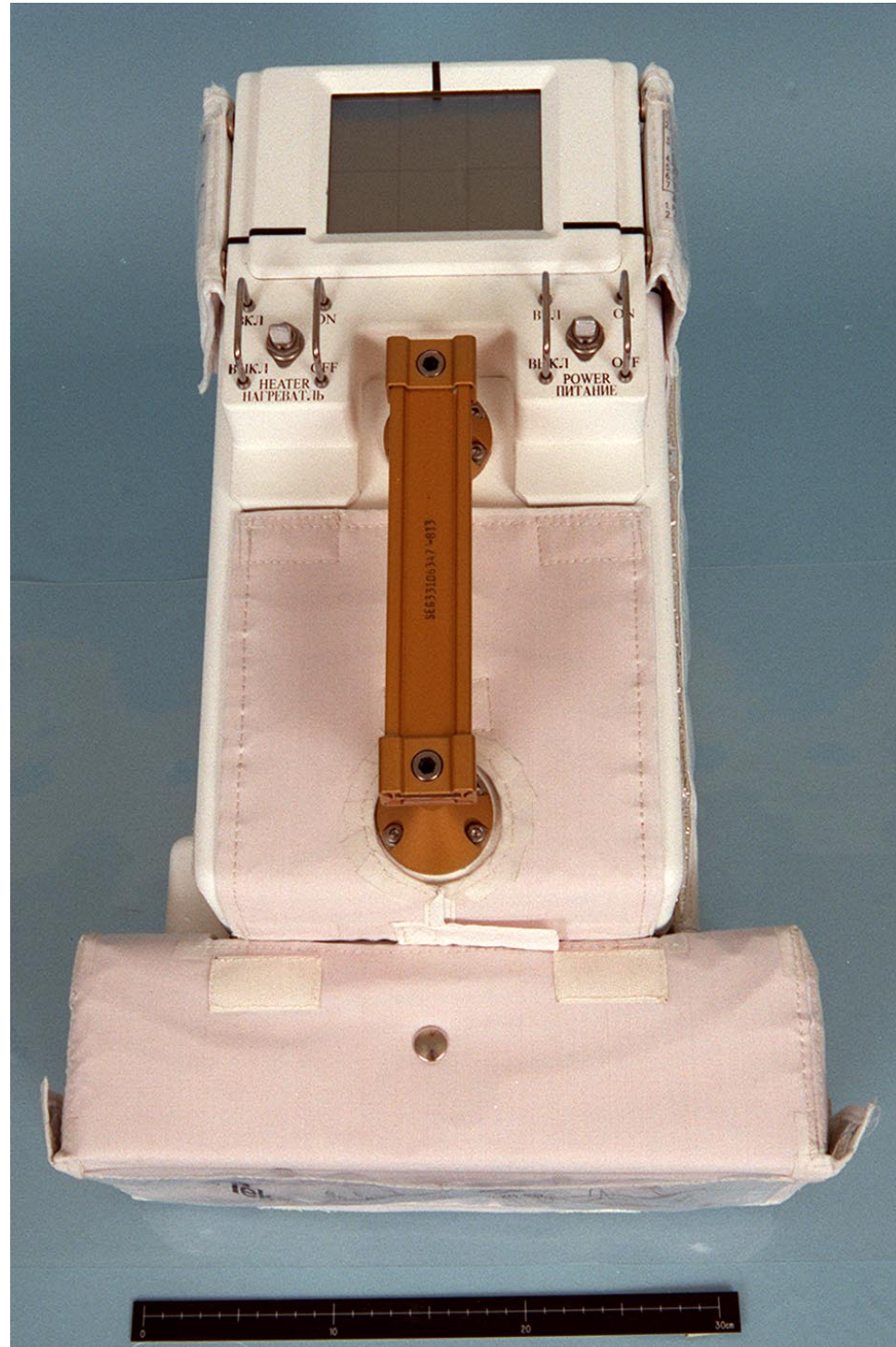

S97-05341

Figure ISS-48 SPSR Hardware, Top View, Showing LCD

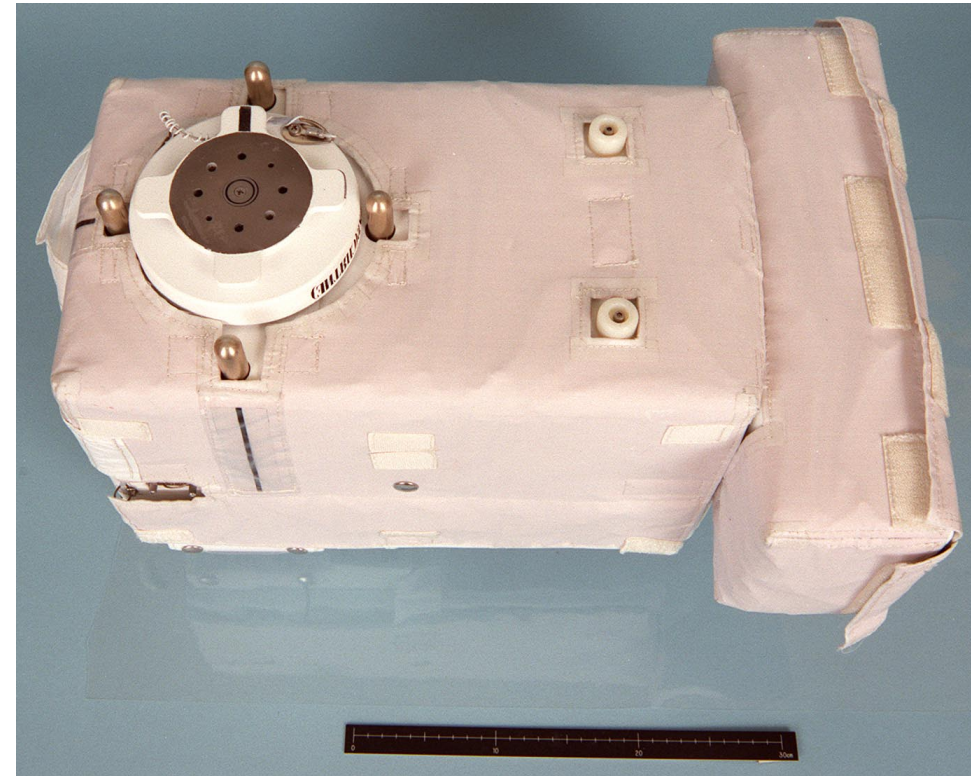

S97-05337

Figure ISS-49 Bottom View, Showing Aperture Cover and Four Position Sensors



S97-05336

Figure ISS-50 Close-Up of Position Sensors



The reflectometer unit power is provided by the battery pack and regulated by the power subsystem. The power subsystem converts the 17 volt DC battery power to the various voltages required to power the reflectometer lamps, display screen, and position indicators.

High efficiency-switching DC to DC converters will be used to provide these different voltages. This power is distributed to the appropriate systems under control of the data system controller.

The SPSR Data Acquisition and Controls System (DACS) will control all aspects of experiment operations, process and collect the data, format and transfer data to the spacecraft data interface, and condition and distribute power to all SPSR systems.

The heart of the DACS is the microprocessor-based data system controller. It will use a stored program in system Programmable Read Only Memory (PROM) and Electrically Erasable Programmable Read Only Memory (EEPROM) to issue the required control sequences and collect the measurement data. Elapsed time is maintained by the data system controller to time tag experimental data.

The control functions for the DACS are distributed among several subsystems, including the lead sulfide and silicon photodetectors, the light chopper, the tungsten and deuterium lamps, the ECC touch screen, and the position indicators.

The interfaces for the SPSR DACS are shown in Figure ISS-51. The SPSR DACS flight software provides the procedures for spacecraft surface alignment, spectral measurement, and data logging and telemetry.

Flexible SPSR operations during flight can be achieved by defining wavelength intervals, start and end wavelengths, the number of reflectance measurements per scan, and other modifiable parameters found within the flight software as well as performing code modifications.

Reflectance data taken by the reflectometer will be stored in the DACS unit. The DACS is capable of storing data internally for at least 250 scans of the full wavelength range of 250 nm to 2500 nm. Data security will be ensured by storing runs twice.

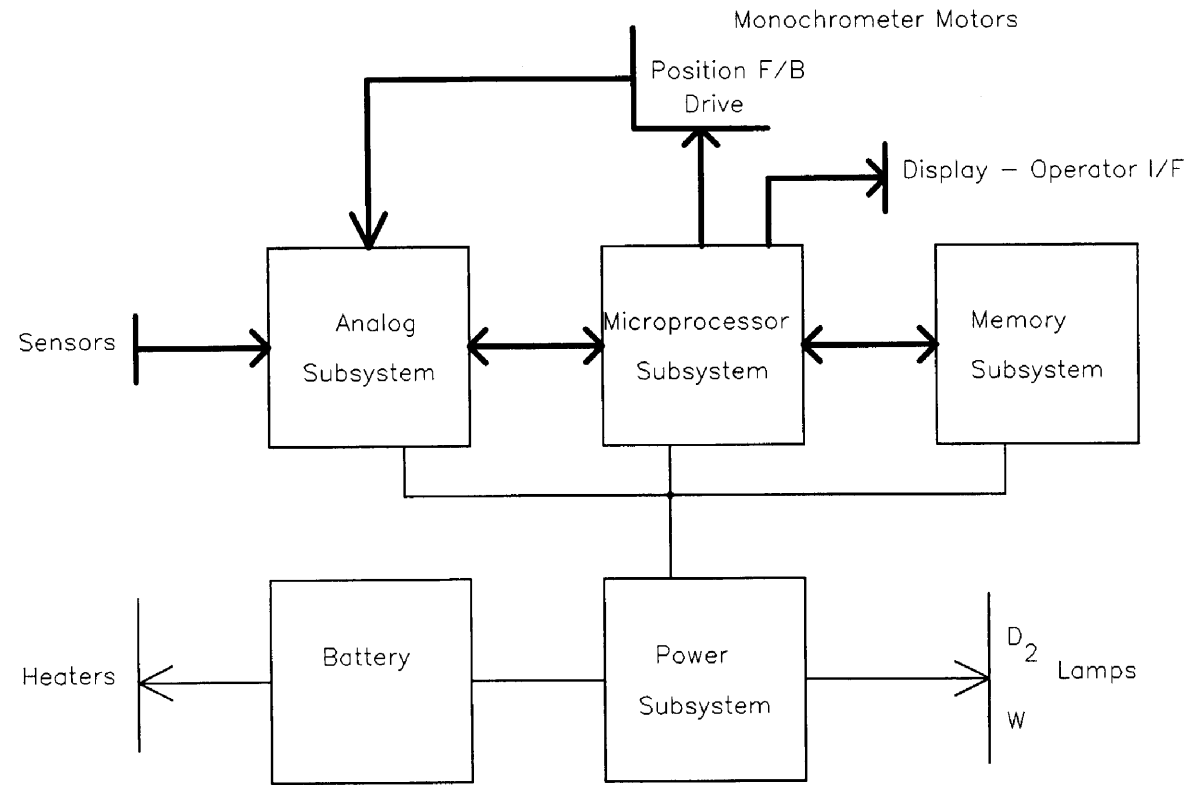

Figure ISS-51 SPSR Data Acquisition and Control System

TABLE ISS.5
DACS CONTROL FUNCTIONS BY SUBSYSTEM

Reflectance	ECC	Power
Wavelength position	Feedback from position indicators	Subsystem power distribution
Slit positioning	Language selection	Power monitor/status
Measurement initiation		
Lamp selection		

BATTERY HOUSING

The SPSR battery housing contains the EMU battery and protect it during the mission. The battery housing contains a standard EMU capture/release mechanism for changing the battery.

To allow the SPSR to fit into a smaller stowage tray, the reflectometer unit and the battery housing were stored as two separate items during launch, then assembled by the STS-89 crew. The battery housing was attached to the reflectometer unit with five captive screws, then the battery was installed.

EMU BATTERY

The battery provides all power necessary for operation of the SPSR. After the battery housing was attached to the reflectometer unit with five captive screws, then the battery is installed.

The battery type is silver-zinc and is rechargeable, and is compatible with Shuttle and International Space Station (ISS) on-board power systems. The battery is rated for 452 watt-hours at 17V DC average discharge. It is load-rated for a minimum of 26.6 A-hrs after eight recharge cycles, 30.0 A-hrs new.

For safety reasons, the battery cell has two relief valves in series in case of excess pressure. Each cell also contains absorbent material to prevent any leakage of electrolyte solution from the battery if both relief valves open. It is stored dry and only filled with the KOH electrolyte prior to launch.



S97-05349

Figure ISS-52 Rear View, without Battery Housing, Battery Electrical Center at Left with the Fuse Cap Underneath

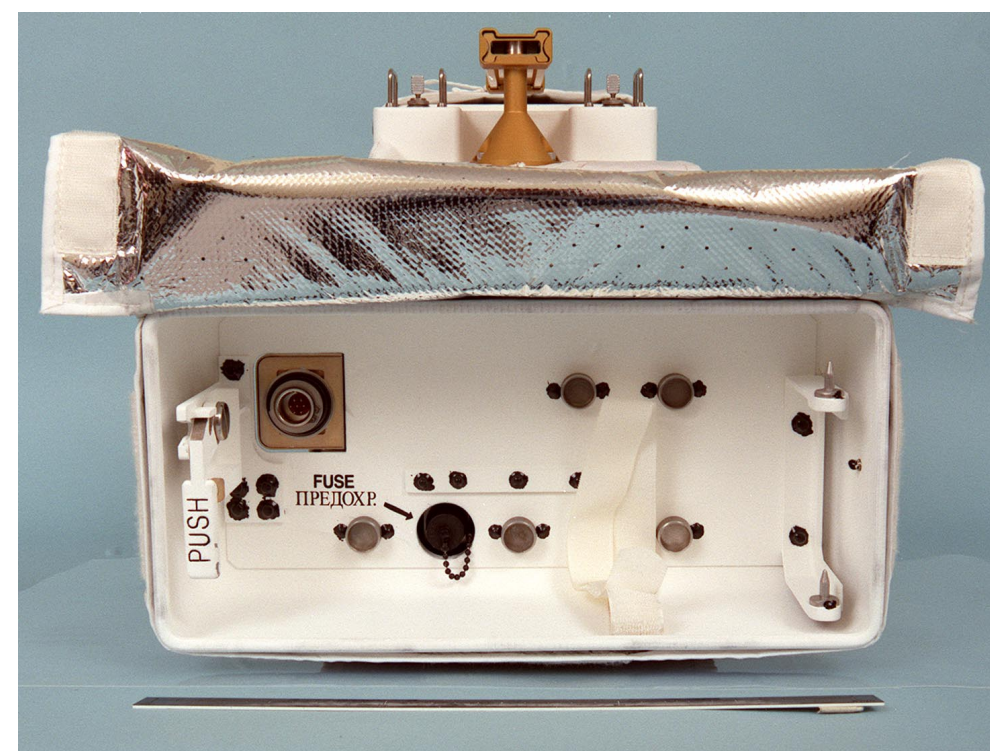

S97-05345

Figure ISS-53 Battery Housing, Battery (Not Shown) Fits into this Housing

EMU BATTERY

P/N: SED13101547-308
Qty: 1
Mass: 4.30 kg
Power: 0
x,y,z: 20.80 x 8.60 x 12.60 cm

SPSR BATTERY HOUSING

P/N: 293-150-0000
Qty: 1
Mass: 1.40 kg
Power: 0
x,y,z: 35.70 x 17.50 x 10.30 cm

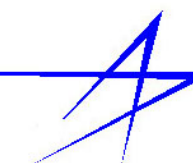

CABLES

The SPSR has a standard RS-232 serial interface. After EVA operations with the SPSR have been completed, the Mir crew will connect the laptop computer to the SPSR interface cable end with the military standard DB-9 connector and connect the cable end with the military standard DB-9 connector to the SPSR. The Mir crew then downloads data to the laptop using SPSR software.

Next, the laptop is taken to the MIPS-2 controller to store SPSR data on optical disk using MIPS software. Telemetry of SPSR data to ground is to be scheduled by the crew. Figure ISS-55 illustrates the SPSR to MIPS to Mir data transfer process.

HARDWARE INTERFACE WITH SYSTEMS

The EEPROM stored data downloads to the MIPS-2 laptop via RS-232 interface. *

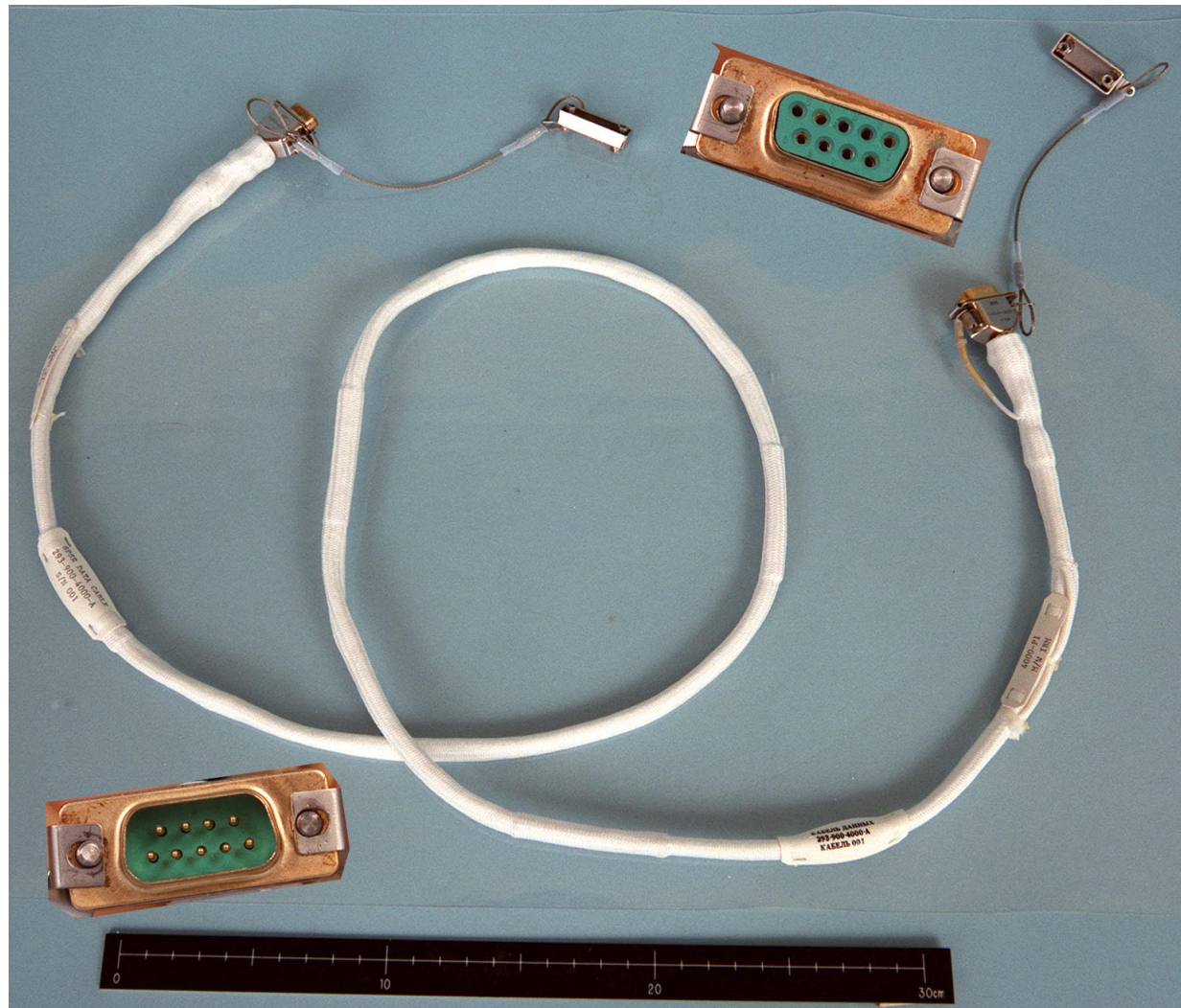

Figure ISS-54
RS232 Cables and Connectors for Transferring Data from SPSR to MIPS Computer

S97-05334

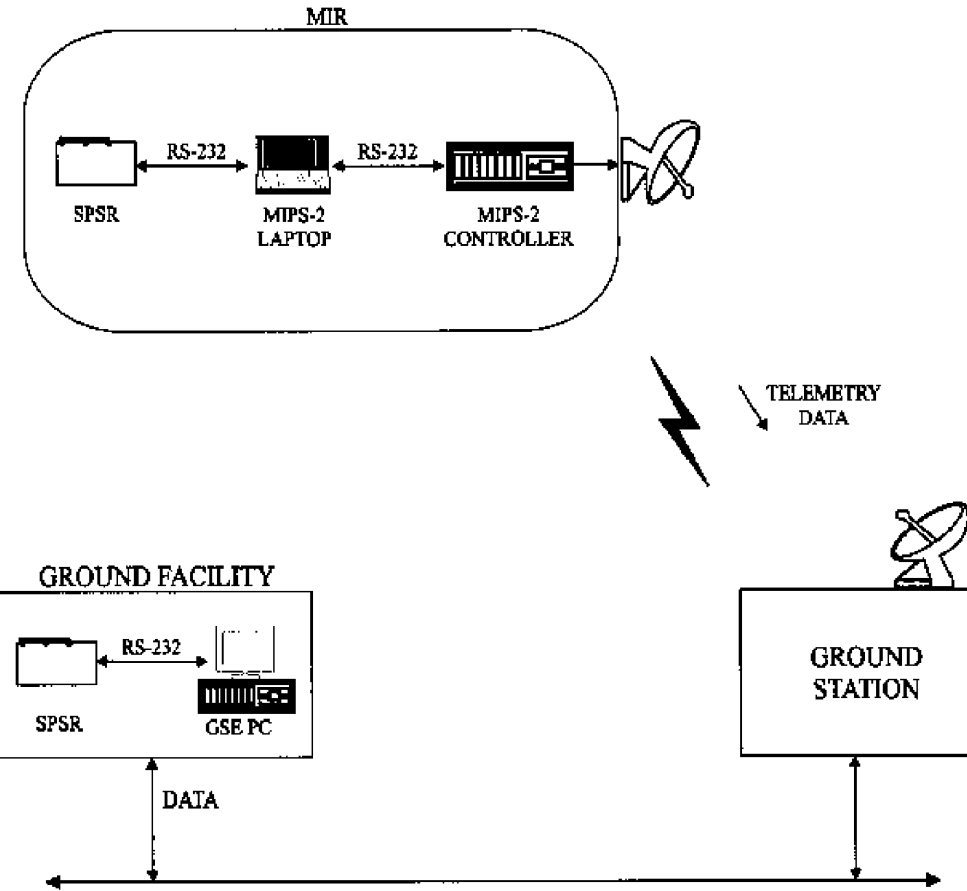

Figure ISS-55 SPSR Data Transfer Diagram

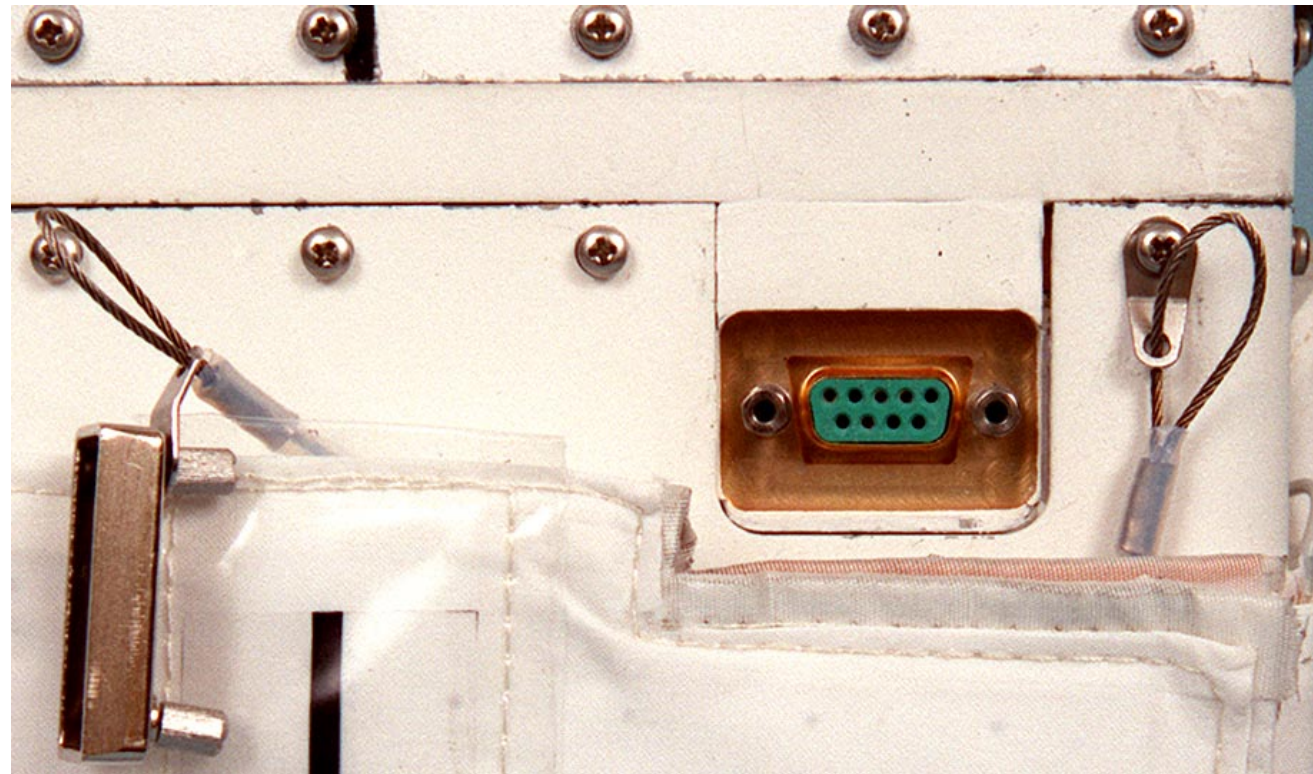

Figure ISS-56 Data Port for RS-232 Cable, Located on Right Side Near Front

S97-05346

ACCESSORIES



S97-05332

Figure ISS-57 MIPS Data Disk



S97-05328

Figure ISS-58 Flight Bag for Storage of SPSR Unit During Mir Mission

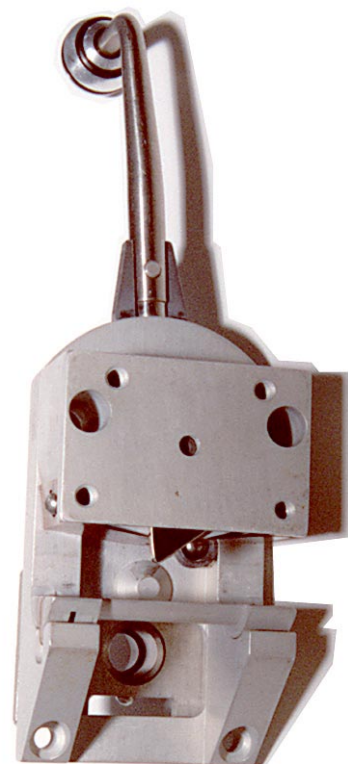

S97-10644

Figure ISS-59 Additional SPSR Hardware



S97-05329

Figure ISS-61 Fuse Kit Showing Spare Fuses



S97-05331

Figure ISS-62 Aperture Cover Top and Bottom

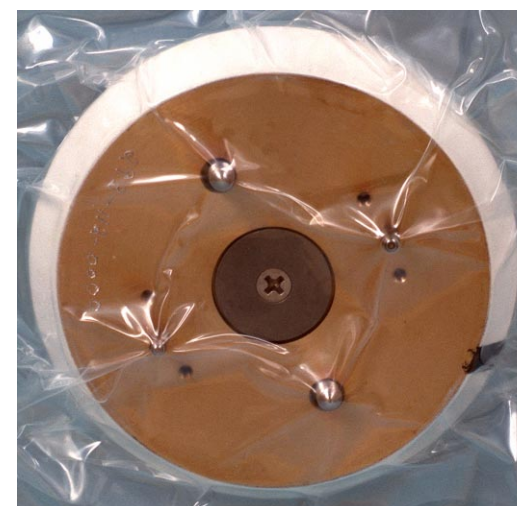

S97-05330

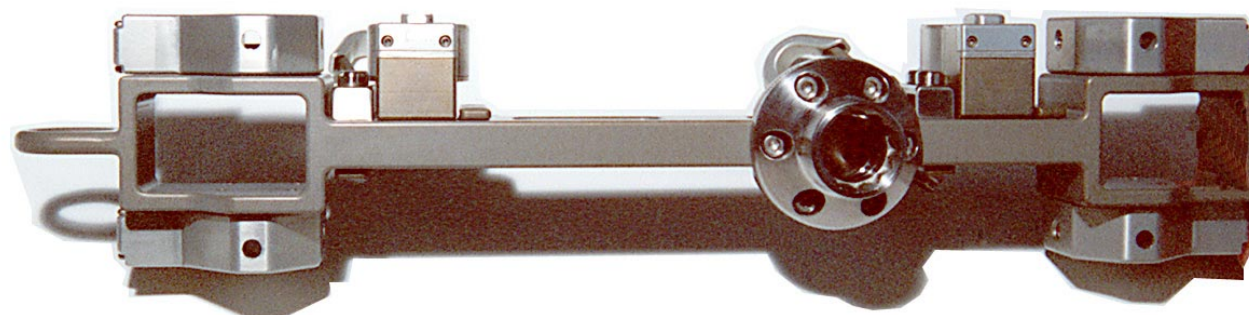

S97-10646

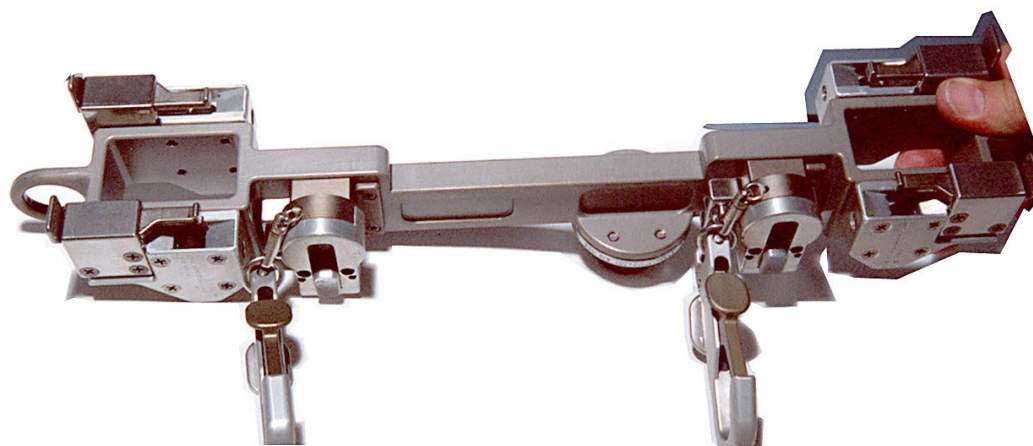

S97-10647

Figure ISS-60 Additional SPSR Hardware

SPSR FUSE KIT

P/N: 293-800-2000
 Qty: 1
 Mass: 0.02 kg
 Power: 0
 x,y,z: 4.10 x 3.70 x 0.90 cm

SPSR FLIGHT BAG

P/N: 293-170-2000
 Qty: 1
 Mass: 0.10 kg
 Power: 0
 x,y,z: 30.20 x 29.50 x 0.13 cm

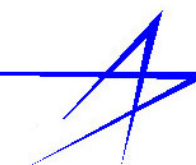

TEST OF PORTABLE COMPUTER SYSTEM HARDWARE (TPCS)

HARDWARE DESCRIPTIONS

Hardware required for this experiment is listed in Table ISS.6. The major components of the Test of Portable Computer System (TPCS) are shown in a hardware system interconnect block diagram for operation aboard the Mir Station.

The TPCS is an International Space Station (ISS) Risk Mitigation experiment designed to provide information on the effects of space radiation on computer systems, namely single event upsets (SEUs) that occur when the computer hardware suffers from space radiation strikes in volatile memory.

The TPCS experiment places the ISS Computer System into the radiation environment of low earth orbit and examine the effects of radiation on the communications and data storage methods used

TABLE ISS.6
EXPERIMENT FLIGHT HARDWARE

HARDWARE TITLE	PART#/SERIAL#
IBM ThinkPad 760ED	SEM46115860-301
Power Supply Unit	SEM46115859-301
Audio/Video Cable	SEM46115863-301
Power Cable	SEM46115861-301
ThinkPad/PSU Cable	SEM46115862-301
Hard Drive	29H8928
Components Bag	SEM46115864-301
External Floppy Drive	SEM46115865-301

within the Portable Computer System (PCS). Software will measure and record the SEUs that occur during testing. This data is taken and stored during different mission phases, and is kept on the TPCS hard drives for data evaluation on the ground.

LAPTOP COMPUTER

The laptop computer is an IBM 760ED ThinkPad with an Intel Pentium Processor 133 MHz

microprocessor. It has 48 MB of RAM on an add-on card. The user interfaces with the laptop computer via a keyboard with a pointing device and a display. The display features a Liquid Crystal Display (LCD) with 65,536 colors, 800 by 600 resolution super Video Graphics Array (VGA), and brightness and contrast control. An internal four speed CD-ROM Drive and a 1.2 GB Hard Drive are used for data storage and programming. An internal battery is used to allow the system to function without a power supply for short periods of time.

External interfaces available are headphone jacks, audio-in jack, video-out and video-in jack. System status indicators show the current computer status by their on/off states or colors (green and orange). Each indicator is identified with a symbol.

The laptop computer features, connectors, switches, and indicators are listed and described in Tables ISS.7, ISS.8, ISS.9, and ISS.10.

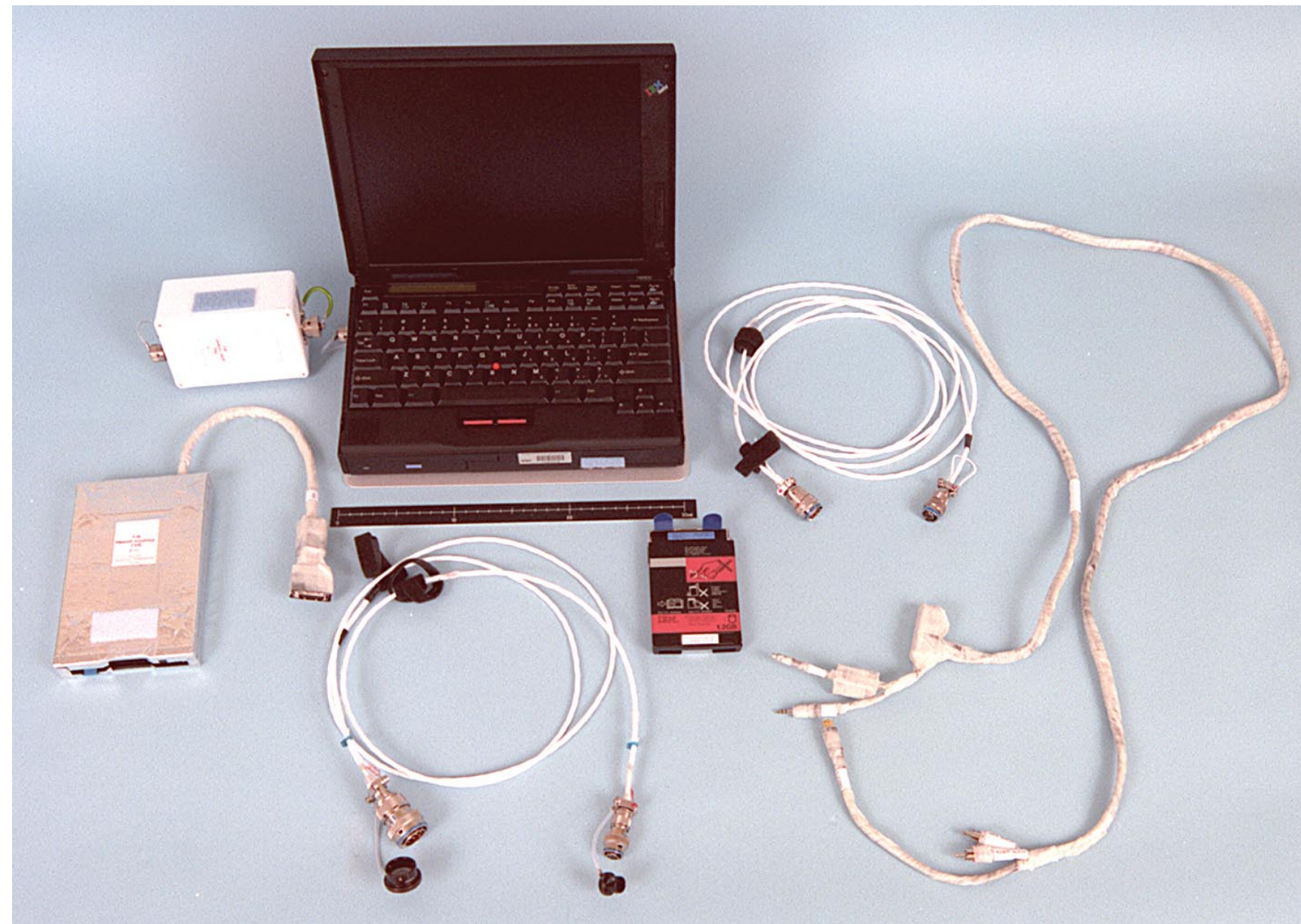

Figure ISS-63 TPCS Hardware

S97-10593

D.I.D.

IBM ThinkPad Portable
Computer System Assy.

D.I.D.

Laptop Computer

D.I.D.

Test of Portable
Computer System
Hardware

Principal Investigator:
Rod Lofton
NASA/JSC/OZ2
(281)244-7443

TPCS SYSTEM

DID#: SDG39129270
Power Consumption:
64 W
100W (w/camcorder)
Start-Up Current:
60 amps, 0.2 msec
On-board Elect. Supply:
DC source 23-32 V
Insulation Resistance:
20 MOhm
(1 MOhm high humidity)
Operational Life:
No info
Shelf Life:
No info

TABLE ISS.7
MAIN FEATURES AND CONTROLS

FEATURE	FUNCTION
1. Color LCD	Displays the computer output and can be moved to any desirable viewing angle.
2. Built-in Microphone	Captures sound and voice and records them to the hard drive.
3. Brightness Control	Moves up or down to adjust the display brightness.
4. Keyboard Risers	Hold the keyboard at an angle and when pushed rearward, lay the keyboard flat with the top of the case.
5. Keyboard	Used to enter data into the computer.
6. External-input-device connector	Used to attach a mouse, external keyboard, or external numeric keypad to the computer.
7. Personal Computer (PC) Card Slots	To accept Personal Computer Memory Card International Association (PCMCIA) cards.
8. PC Card eject button	Ejects the PCMCIA cards from the slot.
10. Release Latches	Release the LCD or keyboard. Forward operation opens the LCD. Rearward operation opens the keyboard.
12. Built-in Speakers	Reproduce recorded sounds.
13. Pointing device	A built-in pointing device that provides a function similar to a mouse.
14. Fn Key	Used to activate the function key functions.
15. LCD Indicator	Shows the current status of the computer and battery power.
16. Volume Control	Volume adjustment for the speakers.
17. Removable CD-ROM Drive	Allows for use of Data CDs, Audio CDs and COSS CDs.
19. CD-ROM Eject Button	Ejects the CD from the drive.

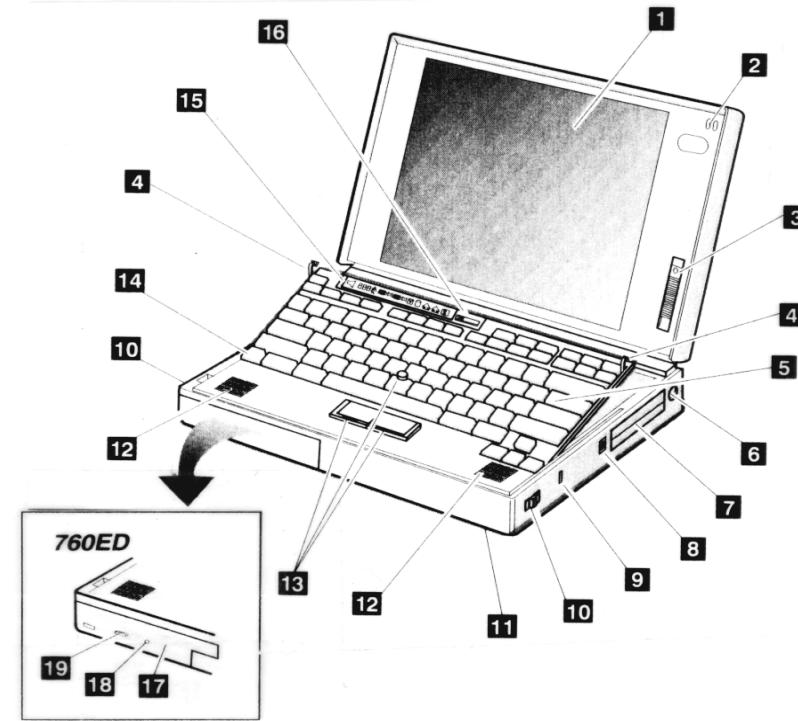

Figure ISS-64 Laptop Computer Main Features and Controls - Front View (See Table ISS.7)

TABLE ISS.8
SYSTEM STATUS INDICATORS

INDICATOR	COLOR	FUNCTION
1. Battery	green/orange	Turns green when enough battery power remains for operation; turns orange when the battery pack is being charged; blinks orange when the battery pack needs changing.
2. Suspend Mode	green	Turns green when the computer is in suspend mode; blinks green when the computer is entering suspend mode or is resuming normal operation.
3. Power on	green	Turns green when the power is on.
4. CD-ROM	green	Turns green when data is read from the CD-ROM drive.

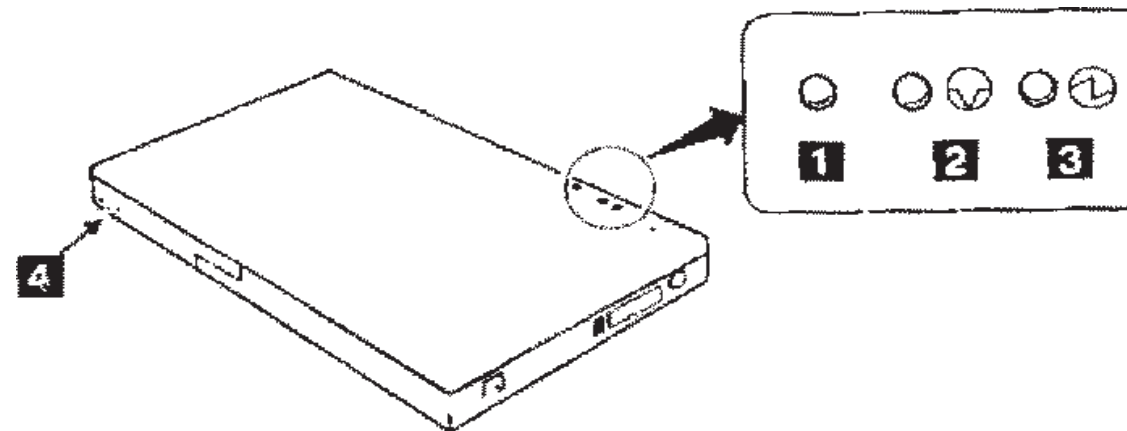

Figure ISS-65 Laptop Computer System Status Indicators

IBM THINKPAD 760ED

P/N: SEM46115860-301
Qty: 1
Mass: 3.87 kg
Power: 0
x,y,z: 21.8 x 31.7 x 6.2 cm



TABLE ISS.9
FEATURES AND CONTROLS (REAR OF COMPUTER)

FEATURE	FUNCTION
1. Rear Door	Covers the connectors at the rear of the computers.
2. Connector Door	Allows for cable connection to the expansion connector when the rear door is closed.
6. System Expansion Connector	Used to connect the expansion unit or port replicator. Two alignment holes are provided on both sides of the connector for the expansion unit guide pins.
7. Power Shutdown Switch	Used to turn the computer off when the application locks up or the computer fails to accept any input.
8. External Display Connector	Where the signal cable of a VGA, Super Video Graphics Array (SVGA), or a compatible display is plugged in.
9. Parallel Connector	Where a parallel-printer signal cable is usually plugged in.
10. Serial Connector	Where a 9-pin, serial device cable is plugged in. The interface is programmable and supports asynchronous communications.
13. Headphone Jack	Where headphone is plugged in. WARNING - To avoid injury from unexpected noise, keep the headphone away from your ears when turning the computer on or connecting the headphone to the computer.
14. Microphone/Line-in Jack	A 3.5 mm diameter jack for connection to an external audio device.
16. Video In/Out	To transfer data from video equipment.
17. Power Switch	Turns the computer on and off.

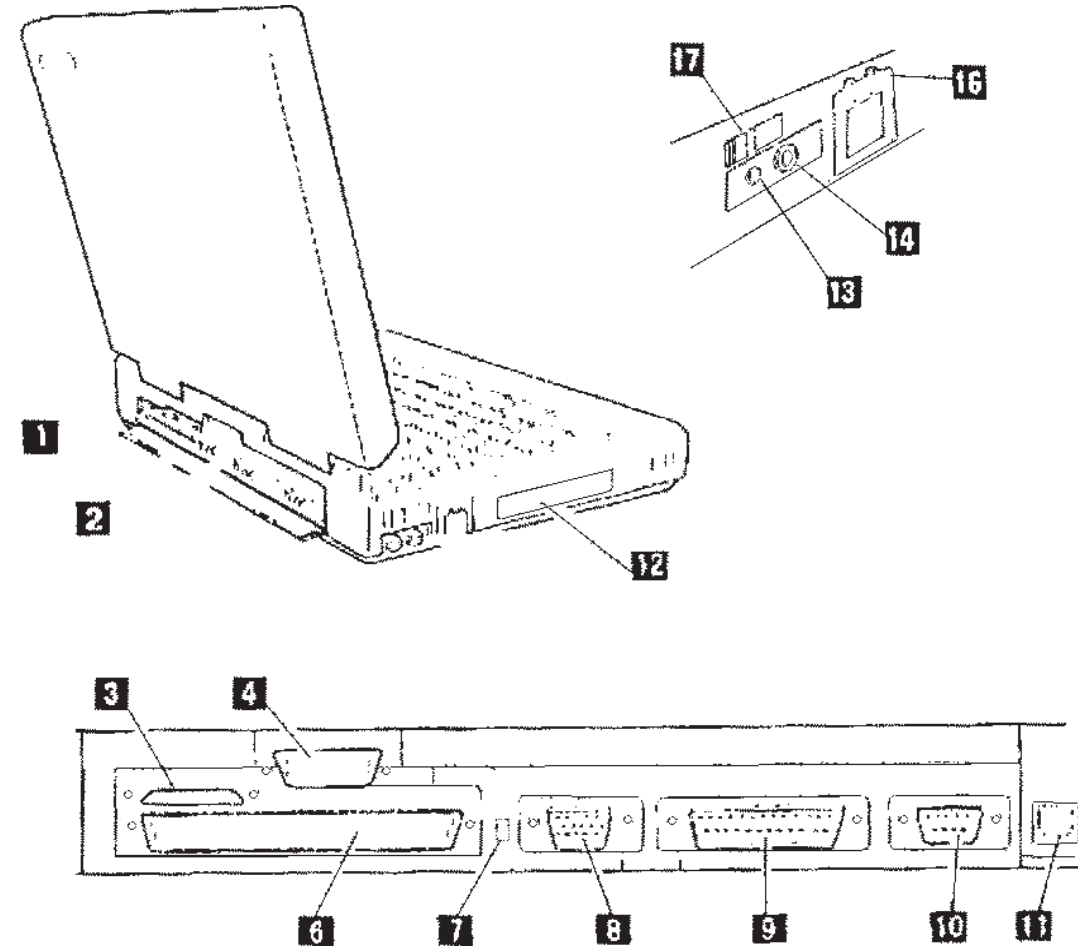

Figure ISS-66 Laptop Computer Features and Controls - Rear View (See Table ISS.9)

TABLE ISS.10
LCD INDICATORS

INDICATOR	COLOR	FUNCTION
1. Speaker		Appears when the speaker sounds.
2. Remaining Battery		Displays the amount of battery remaining.
4. Main Battery Status		Displays the status of the internal battery.
6. Hard Drive		Appears when hard drive is in use.
7. Num. Lock		Indicates the numeric keypad on the keyboard is enabled.
8. Caps Lock		Indicates the Caps Lock is enabled.
9. Scroll Lock		Turns on and off each time the scroll lock key is pressed.

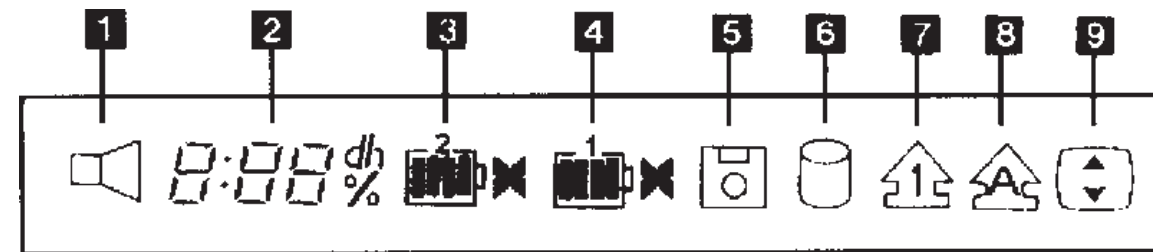

Figure ISS-67 LCD Indicator Panel



S97-10596

Figure ISS-68 Power Supply Unit Side

POWER SUPPLY UNIT (PSU)

The power supply unit is a DC to DC converter that converts the spacecraft power (24 to 32V DC) to the input voltage (approximately 20V DC) that the computer requires.

AUDIO/VIDEO CABLE

The Audio/Video Cable provides stereo audio and video signal from the camcorder to the TV tuner of the TPCS Computer. The length of this cable is approximately 1.92 meters.

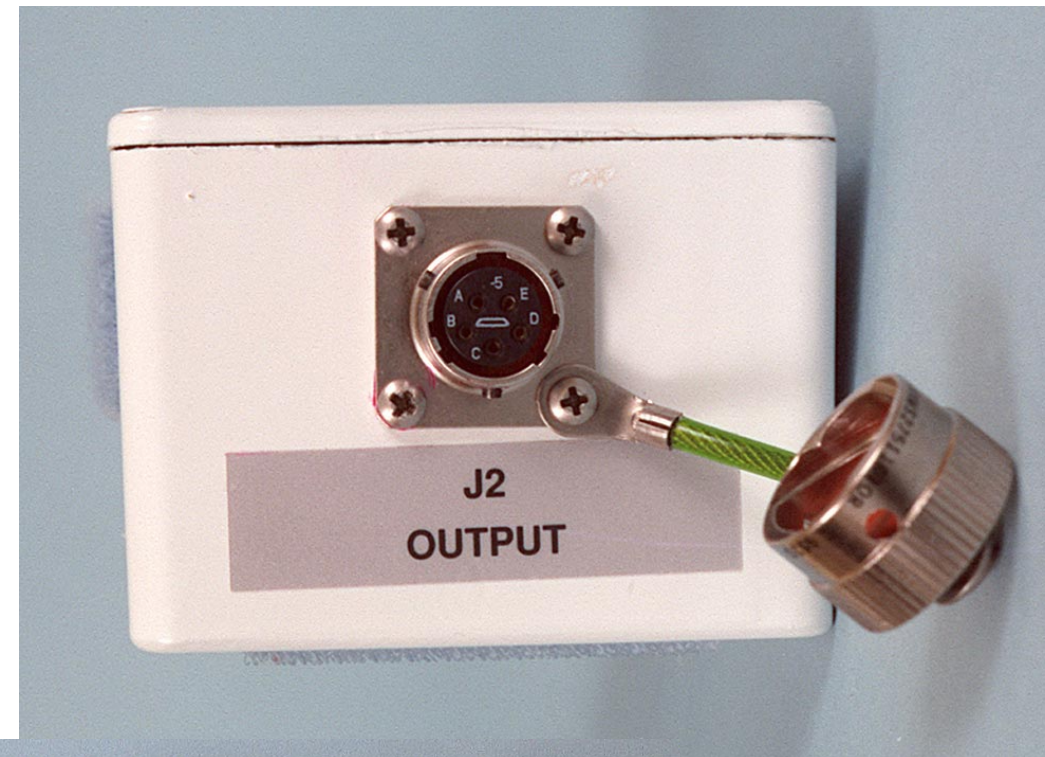

S97-10594

Figure ISS-71
Power Supply Unit Side

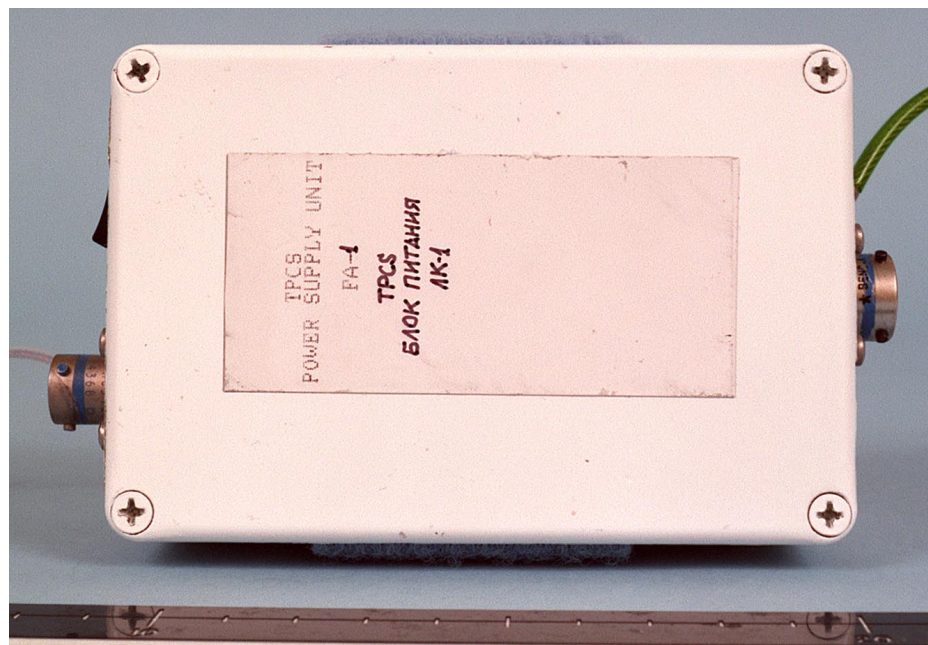

S97-10597

Figure ISS-69 Power Supply Unit Base

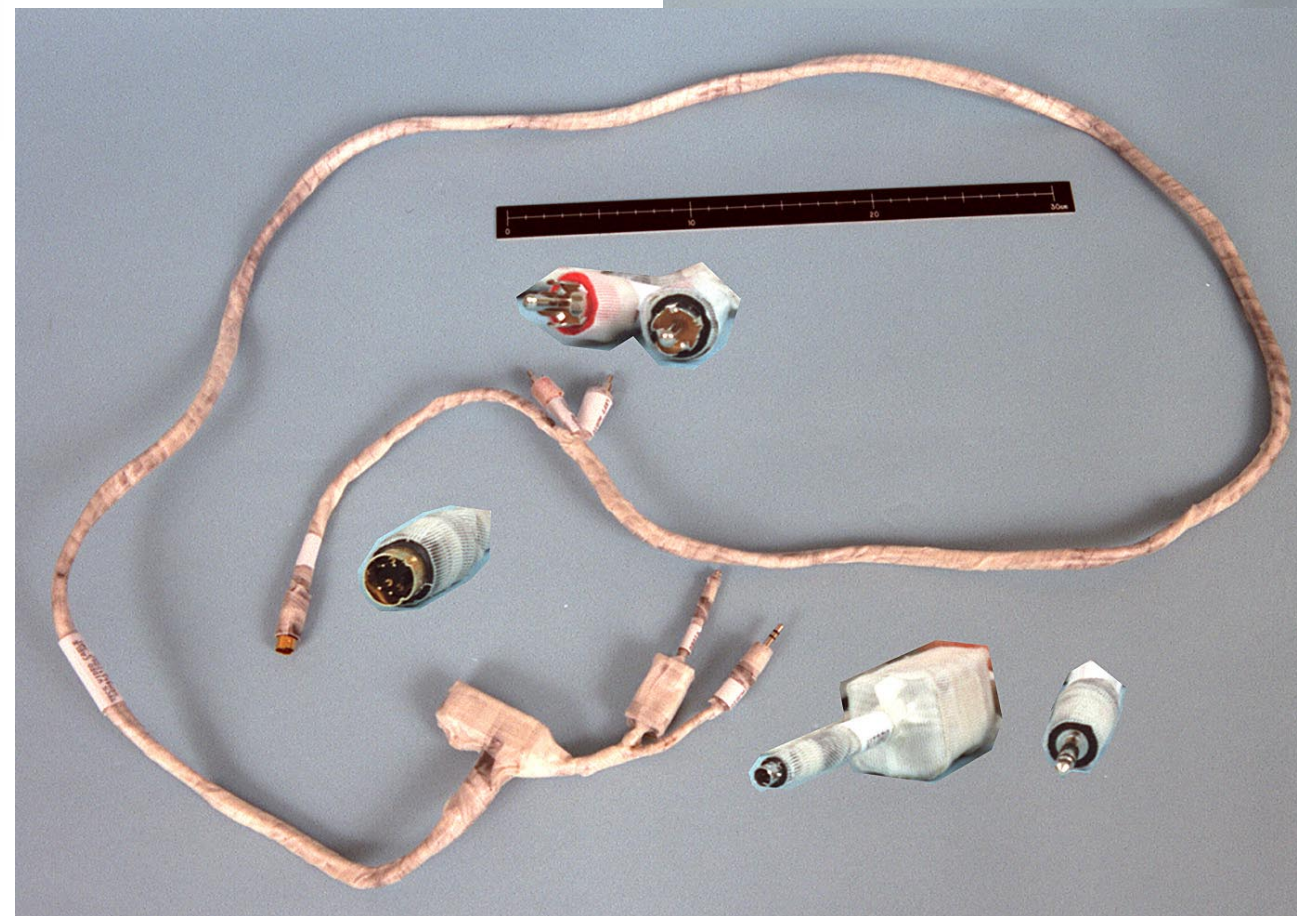

S97-10600

Figure ISS-70 Audio/Video Cable

TPCS AUDIO/VIDEO CABLE

P/N: SEM46115863-301
Qty: 1
Mass: .22 kg
Power: 0
x,y,z: 192 x 2.3 x 7.5 cm
Loc.: N/A

TPCS POWER SUPPLY UNIT (PSU)

P/N: SEM46115859-301
Qty: 1
Mass: .64 kg
Power: 0
x,y,z: 16.3 x 8.6 x 6.3 cm
Loc.: N/A



POWER CABLE

The Power Cable provides the connection between the Payload Utility Panel (PUP) in Priroda and the PSU input. The length of this cable is approximately 2 meters.

THINKPAD/PSU CABLE

The ThinkPad/PSU Cable provides the connection between the PSU output and the TPCS Laptop. The length of this cable is approximately 3 meters.

HARD DRIVE

The hard drive with the latest version of the software is installed inside the computer.

WARNING: The hard disk drive is a very delicate device that requires careful handling.

To install the current hard disk drive:

1. Turn off the power supply switch on the computer and remove power by unplugging the power cable.
2. Open the LCD, then open the keyboard.
3. Remove the battery pack.
4. Insert the hard drive with the software. Press on the shaded area on the hard disk drive until it snaps into the connector.
5. Reinstall the battery pack.
6. Close the keyboard. This completes the installation of the hard disk drive.
7. Reconnect the Power Cable and turn on the power supply switch and the computer.
8. Verify the computer boots from the hard drive and displays the main "Windows 95" screen.

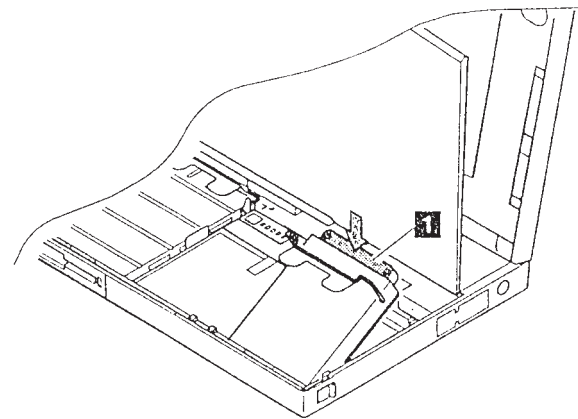
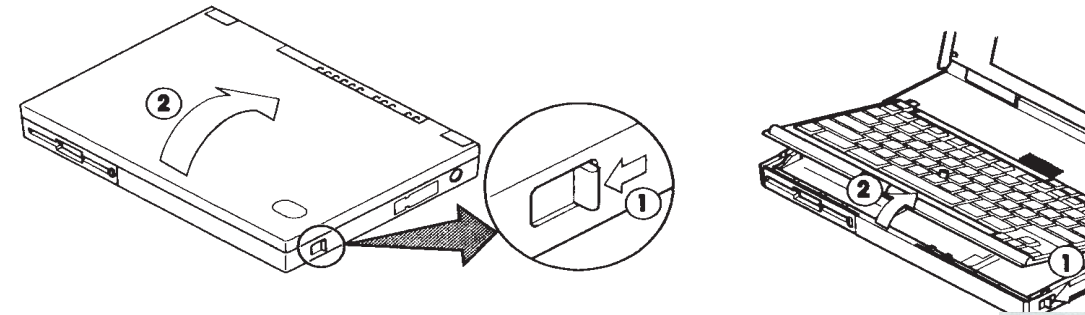

Figure ISS-72 Installation of the Hard Drive

NOTE: The 760 model opens by the screen instead of the front of the keyboard

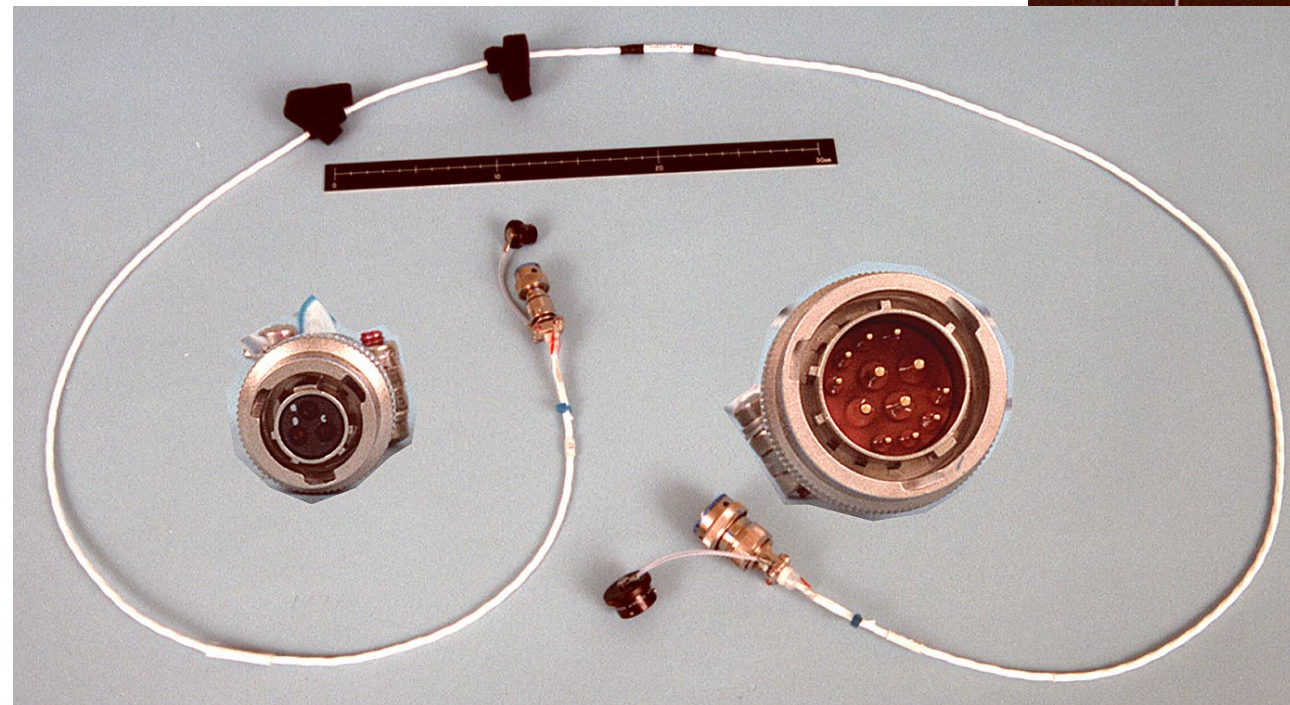

Figure ISS-73 TPCS Power Cable

S97-10603



Figure ISS-74 TPCS Hard Drive

S97-10595

TPCS POWER CABLE

P/N: SEM46115861-301
 Qty: 1
 Mass: .16 kg
 Power: 0
 x,y,z: 182 x 2.7 2.7 cm

TPCS HARD DRIVE

P/N: 29H8928
 Qty: 1
 Mass: .18 kg
 Power: 0
 x,y,z: 11.8 x 7.4 1.8 cm



COMPONENTS BAG

The Components Bag is a stowage bag that will contain the components for the TPCS for transfer to Mir (P/N: SEM46115864, Qty: 1, Mass: .87 kg, Power: 0, dimensions: 35.5 x 24.0 x 23.5 cm).

EXTERNAL FLOPPY DRIVE (EFD) (SEM46115865-301)

The External Floppy Drive provides a 3.5 inch, 1.44MB floppy disk capability to the TPCS. The EFD is connected to the rear panel connector FO1 of the IBM ThinkPad 760ED. The cable connecting the EFD to the ThinkPad is an integral part of the EFD.

HARDWARE INTERFACE WITH SYSTEMS

The TPCS has a power interface with the PUP A in the Priroda Module.

SPECIAL HARDWARE INTERFACES

The TPCS has the capability to act as a Crew On-Orbit Support System (COSS) replacement. The interconnects to the laptop are through the Audio/Video Cable. The camcorder system can be found in the COSS documentation. *

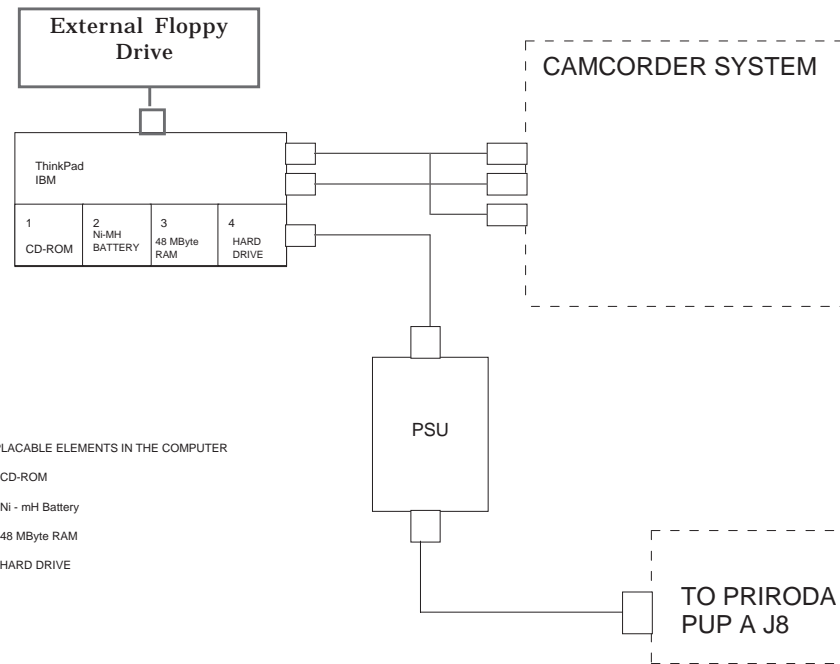

Figure ISS-76 TPCS Schematic for Operation Aboard Mir Station



Figure ISS-77 TPCS External Floppy Drive Interfaces S97-10599

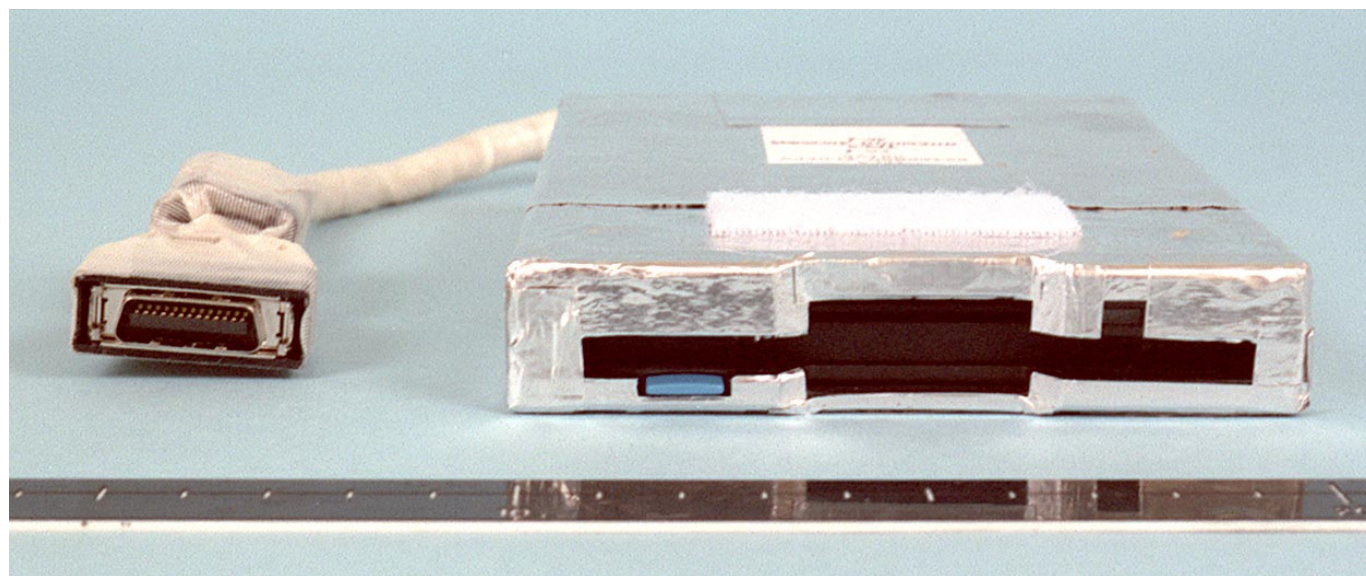

Figure ISS-75 TPCS External Floppy Drive

S97-10598

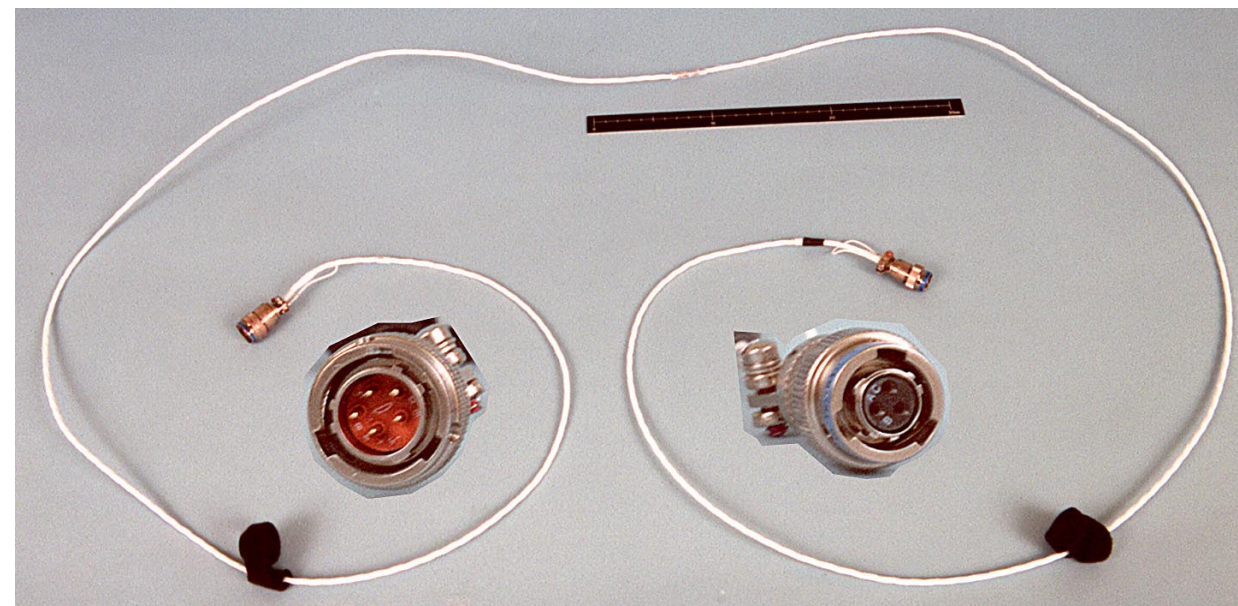

Figure ISS-78 ThinkPad/PSU Cable

S97-10569

TPCS THINKPAD/PSU

P/N: SEM46115864-301
Qty: 1
Mass: .16 kg
Power: 0
x,y,z: 303 x 2.2 x 2.2 cm

TPCS EXTERNAL FLOPPY DRIVE

P/N: SEM46115865-301
Qty: 1
Mass: .46 kg
Power: 0
x,y,z: 18 x 11 x 2.4 cm

